



HEIDENHAIN



Evaluation Electronics

For Metrology Applications

For many metrology applications, ranging from simple measuring stations to complex inspection systems with multiple measuring points, HEIDENHAIN supports you with compatible evaluation electronics.

The functionality always orients itself to the specific application. Whether it is an SPC inspection station, a tool presetter, a profile projector, a measuring microscope, or a manual coordinate measuring machine, the **evaluation electronics from HEIDENHAIN for metrology applications** are the right choice for measurement tasks. There is even a CNC option for the automation of measurement tasks.

Digital readouts from HEIDENHAIN for manually operated machine tools

optimally support the operator with well-proven cycles for milling, drilling, and turning. You can find these digital readouts on the Internet at www.heidenhain.de or in the *Digital Readouts and Linear Encoders for Manually Operated Machine Tools* brochure.



Evaluation electronics for 2-D and 3-D measuring tasks



Evaluation electronics for measuring and testing tasks

This brochure supersedes all previous editions, which thereby become invalid. The basis for ordering from HEIDENHAIN is always the brochure edition valid when the order is made.

Standards (ISO, EN, etc.) apply only where explicitly stated in the brochure.

Further information:
 Comprehensive descriptions of all available interfaces as well as general electrical information are included in the *Interfaces of HEIDENHAIN Encoders* brochure, ID 1078628-xx.
 You can download the operating instructions in the desired language free of charge from the HEIDENHAIN homepage.

Contents

Overview		
	Selection guide for 2-D and 3-D measuring tasks	4
	Selection guide for measuring and testing tasks	6
Specifications		
2-D and 3-D measuring tasks	QUADRA-CHEK 2000 – evaluation unit for reliable 2-D measurement	8
	QUADRA-CHEK 3000 – evaluation unit for intuitive 2-D and 3-D measurement	12
	IK 5000 QUADRA-CHEK – evaluation unit as universal PC package solution	16
Measuring and testing tasks	ND 287 – evaluation unit for measuring and testing stations	20
	GAGE-CHEK 2000 – evaluation unit for reliable 1-D measured-value acquisition	24
	ND 2100G GAGE-CHEK – evaluation unit for multipoint inspection apparatuses	26
	EIB 700 – evaluation unit with measured-value memory	28
	IK 220 – evaluation unit as a PC solution	30
Mounting		
Dimensions and Installation	ND 200	32
	EIB 700	33
	ND 2000	34
	QUADRA-CHEK 2000 and GAGE-CHEK 2000	36
	QUADRA-CHEK 3000	38
Accessories		
	Adapter connectors and calibration/demo parts	40
	External control elements	41
	Optical edge detector	42
Electrical connection		
	Interfaces	
	Overview	43
	Encoder inputs	47
	Switching inputs/outputs of the ND 287	51
	Software	53

Selection guide

2-D and 3-D measuring tasks

	Screen	Axes		Functions
		Length	Angle	
QUADRA-CHEK 2000 Evaluation electronics for: <ul style="list-style-type: none"> • Profile projectors • Measuring microscopes • 2-D measuring machines 	Color touchscreen	3 (XYZ or XYQ), one of which is a software option		<ul style="list-style-type: none"> • Acquisition of 2-D geometry features through measurement, design, and definition of geometries • Measuring point acquisition via crosshairs • Creation of measuring programs (teach-in) • Entry of tolerances and graphic display of measurement results • Creation and output of measurement reports • User administration • Measure Magic: automatic recognition of geometries
QUADRA-CHEK 3000 Evaluation electronics for: <ul style="list-style-type: none"> • Profile projectors • Measuring microscopes • 2-D measuring machines • Video measuring machines • Coordinate measuring machines 	Color touchscreen	4 (XYZQ), two of which are software options		<ul style="list-style-type: none"> • Acquisition of 2-D geometry features through measurement, design, and definition of geometries • Measuring point acquisition via crosshairs • Creation of measuring programs (teach-in) • Entry of tolerances and graphic display of measurement results • Creation and output of measurement reports • User administration • Measure Magic: automatic recognition of geometries
IK 5000 QUADRA-CHEK Evaluation unit as the universal PC package solution for <ul style="list-style-type: none"> • Profile projectors • Measuring microscopes • Video measuring machines • Coordinate measuring machines 	PC screen	3 (XYZ)	1 (Q)	<ul style="list-style-type: none"> • Measurement of 2-D and 3-D features (depending on the version) • Measuring point acquisition via crosshairs • Programming of features and parts • Graphic display of measurement results • Entry of tolerances • Import of CAD drawings for direct comparison • 3-D profiling (option; only with touch probe)
3 (XYZ)		–		
3 (XYZ)		1 (Q)		
3 (XYZ)		1 (Q)		
2 (XY)		1 (Q)		
3 (XYZ)		1 (Q)		
3 (XYZ)		1 (Q)		
3 (XYZ)		1 (Q)		

Options/Additional functions	Model	Page
<ul style="list-style-type: none"> • Additional encoder input • Optical edge detection 	QC 2013	8
	QC 2023	
	QC 2093	



QUADRA-CHEK 2000

<ul style="list-style-type: none"> • Additional encoder input • Video edge detection • Assisted focus • Optical edge detection • Support for 3-D measuring applications 	QC 3014 NC	12
	QC 3024 NC	



QUADRA-CHEK 3000

–	IK 5294	16
3-D; touch probe	IK 5293	
Optical edge finder	IK 5394-EG	
3-D; zoom and light control; video evaluation; touch probe	IK 5394-3D	
CNC; optical edge finder	IK 5493	
CNC; video evaluation; zoom and light control; autofocus	IK 5494-2D	
CNC; 3-D; video evaluation; touch probe; zoom and light control; autofocus	IK 5494-3D	
CNC; 3-D; video evaluation; TP 200 touch probe; zoom and light control; autofocus	IK 5594	



IK 5000 QUADRA-CHEK

Selection guide

Measuring and testing tasks

	Screen	Axes Length Angle	Functions
ND 200 Evaluation unit for <ul style="list-style-type: none"> • Measurement equipment • Adjustment and inspection equipment • SPC inspection stations 	Monochrome	1 (adjustable)	–
	Color	Up to 2 (adjustable)	Metrological and statistical functions (sorting and tolerance checking, measurement series, SPC)
GAGE-CHEK 2000 Evaluation unit for <ul style="list-style-type: none"> • Positioning equipment • Measuring fixtures 	Color touchscreen	3 (two of which are software options)	<ul style="list-style-type: none"> • Precise capturing of measured values, and spot-on positioning in metrology applications • 100 presets • Measurement series with min. and max. value recording • Recording of the difference between min. and max. values (range) • Manual, continuous, or touch-probe-triggered data transfer • User administration • Configurability of each axis for length or angle display
ND 2100G GAGE-CHEK Evaluation unit for <ul style="list-style-type: none"> • Multipoint inspection apparatuses • SPC inspection stations 	Color	4 (adjustable)	<ul style="list-style-type: none"> • Programming of up to 100 parts • Graphic display of measurement results • Sorting and tolerance checking using tolerance and warning limits • Measurement series with min./max. value storage • Entry of formulas and combinations • Functions for statistical process control (SPC)
		8 (adjustable)	
EIB 700 Evaluation unit for <ul style="list-style-type: none"> • Measuring machines • Testing stations • Multipoint inspection apparatuses • Mobile data acquisition 	PC screen	4 (adjustable)	<ul style="list-style-type: none"> • Precise position measurement, up to 50 kHz updating rate • Programmable measured-value inputs • Internal and external measured-value triggers • Measured-value memory for approx. 250 000 measured values per channel • Connection over standard Ethernet interface to higher-level computer systems
IK 220 Evaluation unit for installation in computer systems with PCI interface for measuring and testing stations	PC screen	2 (adjustable)	<ul style="list-style-type: none"> • Programmable measured-value inputs • Internal and external measured-value triggers • Measured-value memory for 8192 measured values per channel

Options/Additional functions	Model	Page
–	ND 280	Brochure: <i>Digital Readouts</i> ¹⁾
Second encoder for sum/difference display, temperature compensation	ND 287	20
Additional encoder input	GC 2013	12
	GC 2023	
	GC 2093	
–	ND 2104 G	26
	ND 2108 G	
Mounting bracket for 19-inch systems	EIB 741 EIB 742	28
Assemblies for encoder outputs and external inputs/outputs	IK 220	30

¹⁾ Brochure: *Digital Readouts and Linear Encoders for Manually Operated Machine Tools*



ND 287



GAGE-CHEK 2000



ND 2100 G GAGE-CHEK



EIB 741



IK 220

QUADRA-CHEK 2000

Evaluation unit for reliable 2-D measurement

The QUADRA-CHEK 2000 evaluation unit is well suited for mounting on measuring machines, profile projectors, and measuring microscopes with up to three axes. You can measure two-dimensional contour features quickly, simply, and precisely using innovative measuring tools.

Design

Thanks to its industrial design, the QUADRA-CHEK 2000 is ideal for applications both in the measuring room and in a harsh production environment. Its flat aluminum housing with integrated power pack and fanless passive cooling is extremely sturdy and tolerant to negative influences. The unit's straightforward touchscreen, made of specially hardened glass, supports multi-touch gesture control and permits operation with gloves.

Functions

Predefined geometries (e.g., point, line, circle, slot, and rectangle) are available for the measurement of two-dimensional features. The "Measure Magic" function makes measurement especially easy. This function uses the acquired measuring points to automatically select the appropriate geometry. In addition to the measuring functions, you can also use functions for construction and definition—for example, in order to create relationships (distances, angles) between two or more contour features.

You can save your results in a measurement report individually formatted as a PDF or CSV file, or you can print them out from a connected printer. The measuring program can automatically record repetitive parts and then execute them again.



Software options

The QUADRA-CHEK 2000's range of functions can be adapted to specific requirements via software options. You can enable these software options by entering a license key. Please contact HEIDENHAIN for more information.

Intuitive display

All of the information you need is displayed in a clean and easy-to-read layout on the unit's high-resolution, 7-inch screen. Only those functions that are actually available within a given context and situation are shown. The self-explanatory operating controls provide intuitive user guidance.

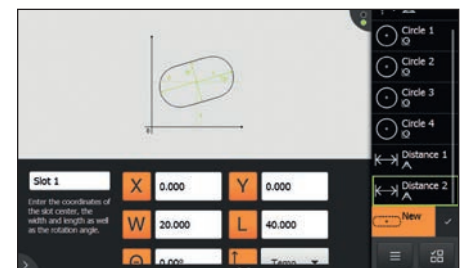



	QUADRA-CHEK 2013	QUADRA-CHEK 2023	QUADRA-CHEK 2093
Axes	3 (XYZ) or (XYQ), one of which can be enabled with a software option		
Encoder interface	$\sim 1 V_{PP} \sim 11 \mu A_{PP}$ EnDat 2.2	\square TTL	1 connection: \square TTL 2 connections: $\sim 1 V_{PP} \sim 11 \mu A_{PP}$ EnDat 2.2
Input frequency	$\sim 1 V_{PP}: \leq 400 \text{ kHz}$ $\sim 11 \mu A_{PP}: \leq 150 \text{ kHz}$	$\leq 5 \text{ MHz}$	$\sim 1 V_{PP}: \leq 400 \text{ kHz}$ $\sim 11 \mu A_{PP}: \leq 150 \text{ kHz}$ \square TTL: $\leq 5 \text{ MHz}$
Subdivision factor	4096-fold (only with 1 V _{PP})		
Display step	Adjustable, max. 8 digits Linear axes XYZ: to 0.00001 mm; angular axis Q: to 0.00001° (00° 00' 00.1")		
Display	7-inch multi-touch screen (15:9); resolution: WVGA 800 x 480 pixels for dialogs, inputs, position values, and graphics functions		
Functions	<ul style="list-style-type: none"> • Acquisition of 2-D geometry features through measurement, construction, and definition • Measuring point acquisition via crosshairs and creation of measuring programs (teach-in) • Entry of tolerances and graphic display of measurement results with user administration • Creation and output of measurement reports • Measure Magic: automatic recognition of geometries 		
Encoder input	One additional encoder input (software option AEI1)		
Edge detection	Optically (software option OED): automatic measuring point acquisition via optical edge detection		
Error compensation	<ul style="list-style-type: none"> • Linear (LEC) and segmented linear (SLEC) using up to 200 points • Squareness calibration; matrix compensation (NLEC) using up to 99 x 99 points 		
Data interface	1x Ethernet 100 Mbit/1 Gbit (RJ45); 1x Hi-Speed USB 2.0 (Type A)		
Other connections	Foot switch for two functions		
Accessories	Multi-Pos and Duo-Pos stands, Multi-Pos holder, power cable, calibration standard, 2-D demo part, adapter connector (HEIDENHAIN TTL pin layout to RSF and Renishaw TTL), foot switch, holder, fiber-optic cable, adapter connector (HEIDENHAIN 11 μA_{PP} pin layout conversion)		
Power connection	AC 100 V to 240 V ($\pm 10 \%$); 50 Hz to 60 Hz ($\pm 5 \%$); $\leq 38 \text{ W}$		
Operating temperature	0 °C to +45 °C (storage temperature: -20 °C to +70 °C)		
Protection EN 60529	IP65; back panel: IP40		
Mounting	Multi-Pos or Duo-Pos stand; Multi-Pos holder; mounting systems with 50 mm x 50 mm hole pattern		
Mass	Unit: $\approx 1.3 \text{ kg}$ Unit with Duo-Pos stand: 1.5 kg Unit with Multi-Pos stand: 2.0 kg Unit with Multi-Pos holder: 1.7 kg		

QUADRA-CHEK 2000

Functions

Measuring point acquisition

The QUADRA-CHEK 2000 allows you to acquire measuring points on flat 2-D contours either manually with crosshairs or automatically, depending on the option installed. A particular advantage is the unit's integrated measuring point acquisition via optical edge detection (OED software option)



Optical edge detection

The OED software option provides you with various tools for detecting edges and defining measuring points. You can acquire measuring points either manually or automatically. With optical edge detection (OED), you can traverse any edge of a contour, and the currently active tool will detect the actual measuring point on its own. This objective measuring point acquisition permits a high degree of repeatability, allowing you to work quickly and with very low measurement uncertainty.

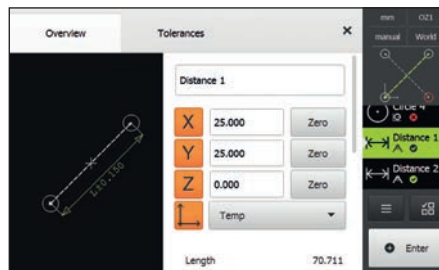

Functional features view

The QUADRA-CHEK 2000 offers you a comprehensive graphic features view. In this view, you can use previously measured geometries to design new geometry features.

Of course, you can also enlarge or reduce this view as well as zoom into features, allowing you to keep a good overview of all the measured geometry features. The features view also makes it possible to add annotations to each feature (e.g., measurement information or informational texts).



Generating geometry features

The QUADRA-CHEK 2000 gives you several possibilities for determining geometries:

- Measuring geometry features
- Constructing features from previously measured features (e.g., distance between two circle centers; angle between lines)
- Defining unmeasurable geometry features

You can also run your created geometry features through a tolerance check.

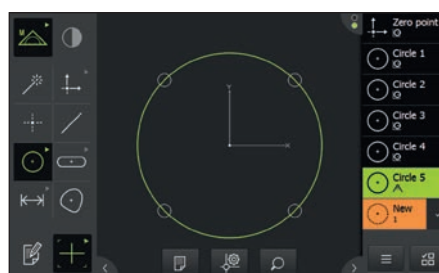

Tolerancing

With the tolerance-adapting function, you can define geometric tolerances for measured or constructed features. Dimensional, positional, and form tolerances can be specified depending on the selected feature. You can also use general tolerancing as per ISO 2768 or decimal tolerancing.

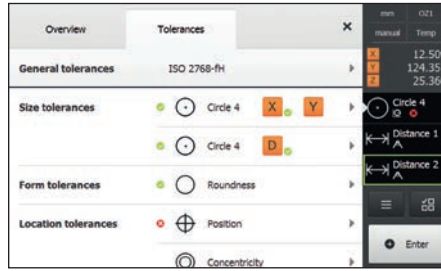

Creating a measuring program

For difficult or repetitive measuring tasks, you can automatically record all of the work steps as a measuring program. The QUADRA-CHEK 2000 learns the presets, sequence of measurements, tolerances, and data-output commands. When the program is run, the QUADRA-CHEK visually leads you to the features to be probed. The program view always provides you with an optimum overview of the process.

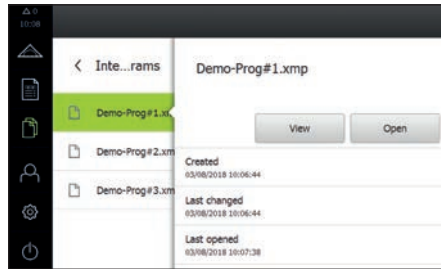

Creating measurement reports

Directly after the measurement, the integrated measurement report function lets you create a report containing the measurement and tolerance results along with other information. Using the demo software, you can also create customized report templates and import them into the unit via the file management. To make a customized template, you can either select a standard template and alter it as you see fit, or you can create entirely new templates. You can then save the created reports in the QUADRA-CHEK unit using the report file format, or as a PDF or CSV file. Alternatively, you also can print the reports from a connected printer.

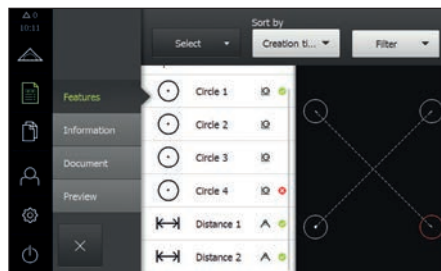

Data interfaces

You can use the data interfaces to output measurement reports as well as to import and export settings and measuring programs. The Ethernet interface enables communication with a PC. You can also connect printers or memory media to the USB port. Network drives and printers can be connected via Ethernet as well. A list of possible printers is available on the Internet at www.heidenhain.de.

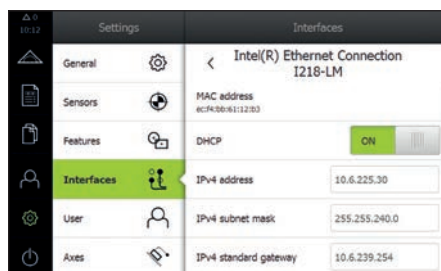

Examples of design capabilities:

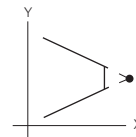

Intersection of two lines

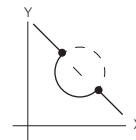

Intersection of line and circle

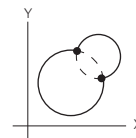

Intersection of two circles

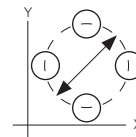

Bolt hole circle formed from three or more circles

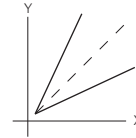

Bisector of two lines

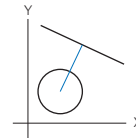

Line constructed from line and circle

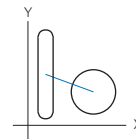

Line constructed from circle and oblong hole

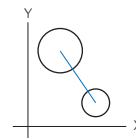

Distance constructed from two circles

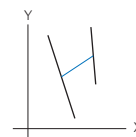

Distance constructed from two lines

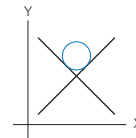

Circle constructed from two lines

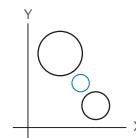

Circle constructed from two circles

QUADRA-CHEK 3000

Evaluation unit for intuitive 2-D and 3-D measurement

The QUADRA-CHEK 3000 evaluation unit is well suited for mounting on measuring machines, profile projectors, measuring microscopes, video testing machines, and coordinate measuring machines with up to four axes. You can measure two-dimensional contour features quickly, simply, and precisely using innovative measuring tools.

Design

Thanks to its industrial design, the QUADRA-CHEK 3000 is ideal for applications both in the measuring room and in a harsh production environment. Its low-profile aluminum housing with integrated power pack and fanless passive cooling is extremely sturdy and tolerant to negative influences. The large touchscreen, made of specially hardened glass, supports multi-touch gesture control and can be operated with gloves.

Functions

Predefined geometries (e.g., point, line, circle, slot, rectangle, sphere, cone, cylinder, and plane) are available for the measurement of two-dimensional and three-dimensional features. The “Measure Magic” function makes measurement especially easy. This function uses the acquired measuring points to automatically select the appropriate geometry. In addition to the measuring functions, you can also use functions for construction and definition—for example, in order to create relationships (distances, angles) between two or more contour features.

You can save your results in a measurement report individually formatted as a PDF or CSV file, or you can print them from a connected printer. The measuring program can automatically record repetitive parts and then execute them again.

Software options

The QUADRA-CHEK 3000's performance range can be adapted through software options to specific requirements. You can enable the software options by entering a license key. Please contact HEIDENHAIN for more information.



Intuitive display

All of the information you need is displayed in a clean and easy-to-read layout on the unit's high-resolution, 12.1-inch screen. Only those functions that are actually available within a given context and situation are shown. The self-explanatory operating controls provide intuitive user guidance.

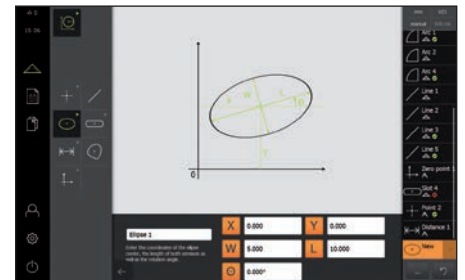



	QUADRA-CHEK 3014 NC	QUADRA-CHEK 3024 NC
Axes	4 (XYZQ), two of which can be enabled with a software option	
Encoder interface Input frequency	$\sim 1 V_{PP} \sim 11 \mu A_{PP}$ EnDat 2.2 $\sim 1 V_{PP}: \leq 400 \text{ kHz}; \sim 11 \mu A_{PP}: 150 \text{ kHz}$	\square TTL $\leq 5 \text{ MHz}$
Subdivision factor	4096-fold (only with 1 V _{PP})	
Display step	Adjustable, max. 8 digits Linear axes XYZ: to 0.00001 mm; angular axis Q: to 0.00001° (00° 00' 00.1")	
Display	12.1-inch multi-touch screen (16:10); resolution: WXGA 1280 x 800 pixels, for position values, dialogs, inputs, graphics functions, and video display (VED software option)	
Functions	<ul style="list-style-type: none"> • Acquisition of 2-D geometry features through measurement, construction, and definition • Measuring point acquisition via crosshairs and creation of measuring programs (teach-in) • Entry of tolerances and graphic display of measurement results with user administration • Creation and output of measurement reports • Measure Magic: automatic recognition of geometries 	
Encoder input	One additional encoder input (software option AEI1)	
Edge detection	<i>Video (software option VED):</i> <ul style="list-style-type: none"> • Automatic measuring point acquisition via video edge detection and programmable light control • Display, archiving, and output of live images <i>Optically (software option OED):</i> <ul style="list-style-type: none"> • Automatic measuring point acquisition via optical edge detection 	
Assisted focus	Assisted focusing of the camera on the object of measurement (software option AF)	
3-D measuring applications	Measured-value acquisition via touch probe (software option 3D)	
Error compensation	<ul style="list-style-type: none"> • Linear (LEC) and segmented linear (SLEC) using up to 200 points • Squareness calibration; matrix compensation (NLEC) using up to 99 x 99 points 	
Data interface	1x Ethernet 100 MB/1 Gbit (RJ45); 3x USB 2.0 Hi-Speed (Type A)	
Other connections	<ul style="list-style-type: none"> • Camera connection¹⁾ (USB 2.0 Hi-Speed (Type A), Ethernet 1 Gbit (RJ45)) • Light control for up to 6 light sources 	
Accessories	Multi-Pos and Duo-Pos stand, Multi-Pos holder, power cable, measuring standard, 2-D demo part, adapter connector	
Power connector	AC 100 V to 240 V (±10 %), 50 Hz to 60 Hz (±5 %), ≤ 79 W	
Operating temperature	0 °C to +45 °C (storage temperature: -20 °C to +70 °C)	
Protection EN 60529	IP65; back panel: IP40	
Mounting	Multi-Pos or Duo-Pos stand, Multi-Pos holder, fastening systems compatible to VESA MIS-D 100	
Mass	Unit: ≈ 3.5 kg; unit with Multi-Pos holder: ≈ 4.1 kg; Unit with Duo-Pos stand: ≈ 3.8 kg; unit with Multi-Pos stand: ≈ 4.5 kg	

¹⁾ Supported camera manufacturer: IDS Imaging Development Systems GmbH;
camera resolution: ≤ 2.0 megapixels, list of released cameras on the Internet at www.heidenhain.de

QUADRA-CHEK 3000

Functions

Acquiring measuring points

The QUADRA-CHEK 3000 allows you to, for example, acquire points on flat 2-D contours either manually with crosshairs or automatically, depending on the option installed. The integrated measuring point acquisition over video edge detection (software option VED) is particularly helpful. Here the video image is displayed in real-time. The evaluation electronics even assume complete control of the illumination.



Optical edge detection

The OED option allows you to use a range of tools for edge detection and for the definition of measuring points. You can acquire measuring points either manually or automatically. With optical edge detection (OED), you can traverse any edge of a contour, and the currently active tool will detect the actual measuring point on its own.



Video edge detection

The VED option provides you with multiple tools for edge detection and for specifying measuring points. You can acquire the points manually or automatically. With the VED automatic measuring point acquisition, you need only approach the position—the active tool automatically finds the actual edge. This objective point measurement permits a high degree of repeatability. This makes it possible for you to work quickly, reliably, and effortlessly, while at the same time maintaining a low degree of measurement uncertainty.

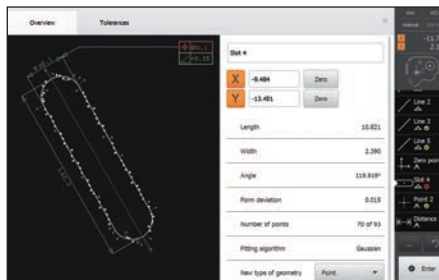

3-D measuring applications

With the 3D option you can use a connected touch probe to acquire the measuring points. The current position values are loaded during probing, and are then used to calculate the geometrical features, such as spheres, cones, or cylinders.

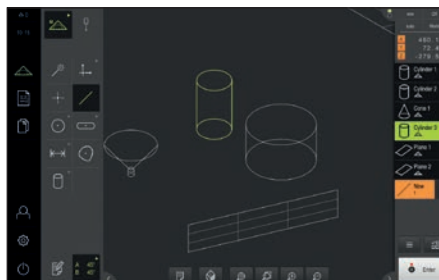

Functional features view

The QUADRA-CHEK 3000 offers you a comprehensive graphic features view. In this view, you can use previously measured geometries to design new geometry features. Of course, you can also enlarge or reduce this view as well as zoom into features, in order to keep a good overview of all the measured geometry features. The features view also makes it possible to add annotations to each feature (e.g., measurement information or informational texts).

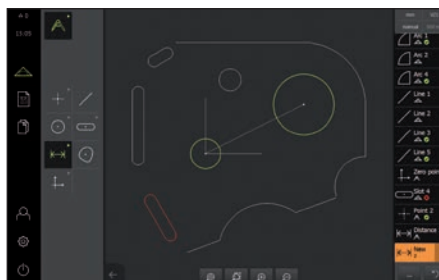

Tolerancing

With the tolerance-adapting function, you can define geometric tolerances for measured or constructed features. Dimensional, positional, and form tolerances can be specified depending on the selected feature. You can also use general tolerancing as per ISO 2768 or decimal tolerancing.

Generating geometry features

The QUADRA-CHEK offers several possibilities for determining geometries:

- Measuring geometry features
- Constructing features from previously measured features (e.g., distance between two circle centers; angle between lines)
- Defining unmeasurable geometry features

You can also run your created geometry features through a tolerance check.

Creating a measuring program

For difficult or repetitive measuring tasks, you can automatically record all of the work steps as a measuring program. The QUADRA-CHEK 3000 learns the presets, sequence of measurements, tolerances, and data-output commands. When the program is run, the QUADRA-CHEK 3000 visually leads you to the features to be probed. The program view always provides you with an optimum overview of the process.

Creating measurement reports

Directly after the measurement, the integrated measurement report function lets you create a report containing the measurement and tolerance results along with other information. With the template designer you can create individually configured reports. You select a standard template and adapt it to meet your needs, or you can create entirely new templates. Measurement reports can be saved in the QUADRA-CHEK 3000 using the .pdf, .csv, and measurement report file formats, or can be printed from a peripheral printer or network printer.

Data interfaces

You can use the data interfaces to output measurement reports as well as to import and export settings and measuring programs. The Ethernet interface enables communication with a PC. You can also connect printers or memory media to the USB port. Network drives and printers can be connected via Ethernet as well. A list of possible printers is available on the Internet at www.heidenhain.de.

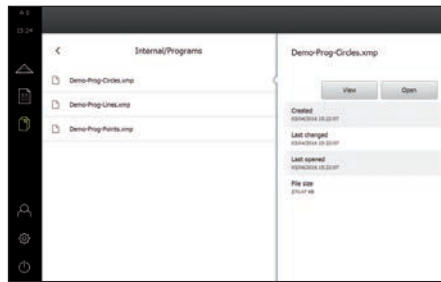
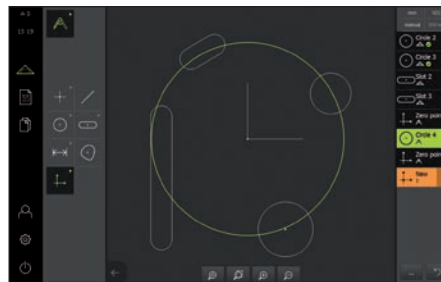
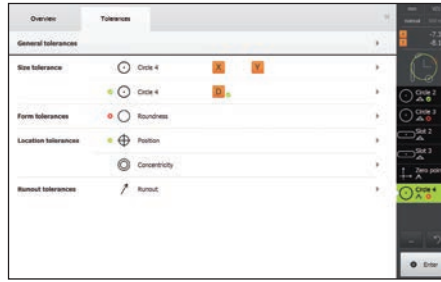

Number	Name	Type	Tolerance	X	Y	Size	Form
1	Slot 1		Pass	3.2733	18.0346	6.9982	0.0096
2	Circle 1		Pass	18.9051	13.3834	4.4864	0.0237
3	Circle 2		Pass	33.3942	8.1324	12.6949	0.0194
4	Slot 2		Pass	-1.4168	3.4769	16.4313	0.0013
5	Circle 3		Pass	11.7516	-2.1643	6.2479	0.0141
6	Slot 3		Fail	2.2869	-18.6200	10.8999	0.0027
7	Line 1		Pass	11.3952	-21.9185	6.8869	0.0321
8	Line 2		Pass	34.9294	-12.9035	10.0243	0.0229
9	Line 3		Pass	-8.3311	2.8393	10.0964	0.0060
10	Line 4		Pass	22.4600	25.1301	10.0318	0.0060

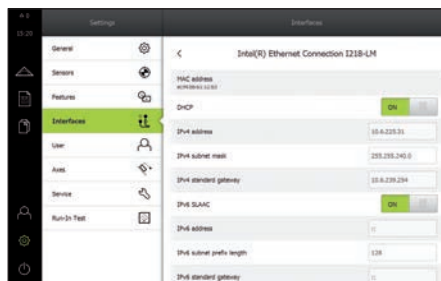

Examples of design capabilities:

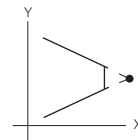

Intersection of two lines

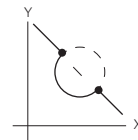

Intersection of line and circle

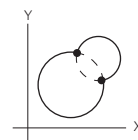

Intersection of two circles

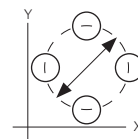

Bolt hole circle formed from three or more circles

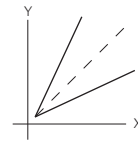

Bisector of two lines

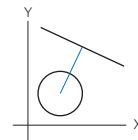

Line constructed from line and circle

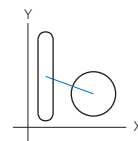

Line constructed from circle and oblong hole

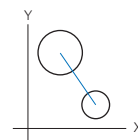

Distance constructed from two circles

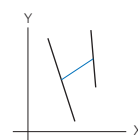

Distance constructed from two lines

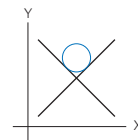

Circle constructed from two lines

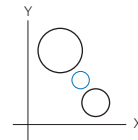

Circle constructed from two circles

IK 5000 QUADRA-CHEK

Evaluation unit as universal PC package solution for measuring machines

The IK 5000 QUADRA-CHEK—the universal PC package solution for 2-D and 3-D measuring tasks—is well suited for both original equipment and retrofitting. It is available in versions for three or four axes, and the optional expansions make it ready for all coordinate measuring technology applications and for video measuring microscopes. You can use it to measure two- and three-dimensional geometries and their relationships.

Implementation

The IK 5000 QUADRA-CHEK consists of the IK 5000 slot card for the PC as well as the additional necessary slot covers and the corresponding PC software. Once it is installed on your PC, you will have a powerful measuring station.

System requirements

The following is necessary for running QUADRA-CHEK (values for 3-D profiling option in italics):

- PC \geq Dual-Core Pentium; 2.66 GHz (*Quad-Core Pentium; 2.8 GHz*)
- Operating systems: Windows Vista, 7, 8, and 10 (32-bit/64-bit)
- RAM \geq 1GB (2GB)
- Hard disk with at least 500MB (1GB) of free memory
- One PCIe slot and one, two, or three additional empty slots (depending on the version)
- Screen resolution: At least 1024 x 768 pixels
- Windows administrator rights for installation, setup, and updating

Configuration

Various versions of the IK 5000 are available. Please see the configuration table for the model designations and various functions supported.

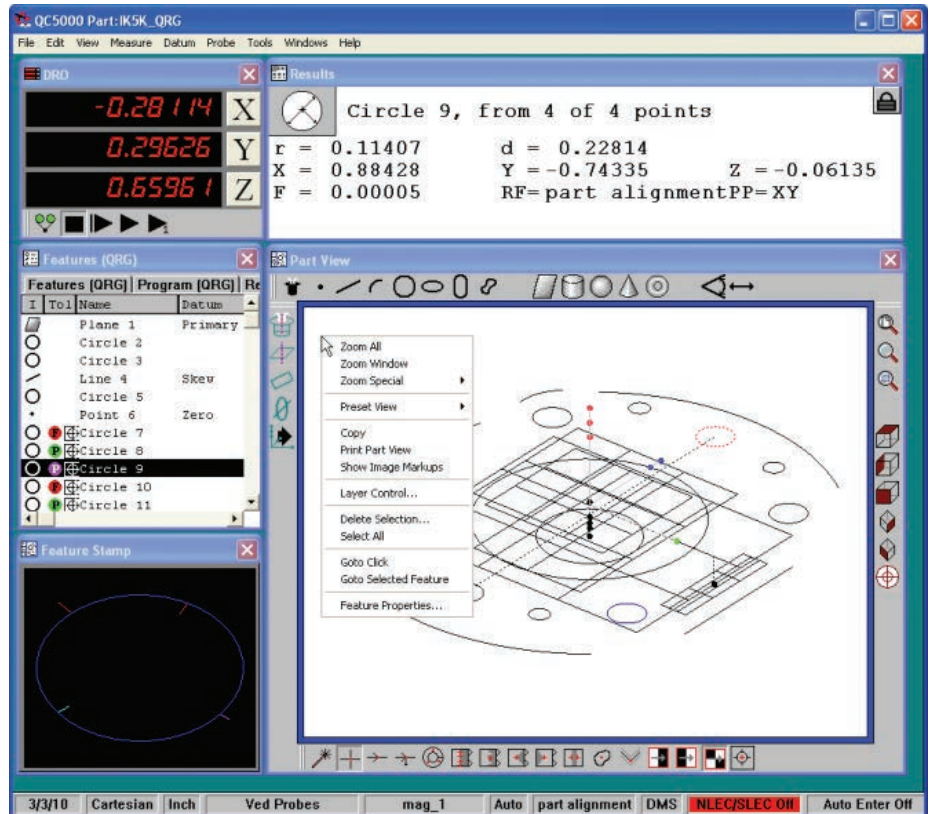

User interface

The IK 5000 QUADRA-CHEK screen shows various configurable windows and tool fields for clear and simple operation.

The **Part View** window shows the measured features with the accepted measuring points. You can also define relationships here.

In the **Live View** (only for versions with video evaluation) you can see a real-time display of the video image.

The **Template** window lists all measured features, relationships and constructed features together with their values and tolerances in tables.

The feature currently being measured is shown in the **Feature Stamp** window. The **Results** window contains all corresponding information.

The **DRO** window shows you the current measuring position.

	IK 5294	IK 5293	IK 5394	IK 5493	IK 5494	IK 5594		
Axes	4 XYZQ	3 XYZ	4 XYZQ	4 XYZQ	3 XYQ	4 XYZQ	4 XYZQ	3 XYZQ
2-D geometries	●	●	●	●	●	●	●	●
3-D geometries	–	●	–	●	–	–	●	●
Optical edge detector	–	–	●	–	●	–	–	–
Video evaluation	–	–	–	●	–	●	●	●
Zoom and light control	–	–	–	●	–	●	●	●
Autofocus	–	–	–	–	–	●	●	●
Touch probes	–	Simple/Universal	–	●	–	–	Simple	High-End (TP 200)
3-D profiling	–	Optional	–	Optional	–	–	Optional	Optional
CNC function	–	–	–	–	●	●	●	●



	IK 5000
Axes¹⁾	3 (XYQ), 3 (XYZ), or 4 (XYZQ)
Encoder inputs* Input frequency	\sim 1 V _{PP} or \square TTL (other interfaces upon request) \sim 1 V _{PP} : differential \leq 1.5 MHz; \square TTL: differential \leq 3 MHz; single-ended \leq 2.5 MHz
Subdivision factor	Up to 100-fold, selectable via dip switch; default setting: 50-fold (only for 1 V _{PP})
Display step ²⁾	Adjustable, max. 7 digits <i>Linear axes XYZ: 1 mm to 0.0001 mm; angular axis Q: 1° to 0.0001° (00° 00' 01")</i>
Display	Via a PC screen
Functions	<ul style="list-style-type: none"> • Measurement of two-dimensional features (2-D) • Measurement of three-dimensional features (3-D)¹⁾ • Measuring point acquisition using crosshairs • Programming of features and parts • Measure Magic: automatic recognition of geometries • Graphic display of measurement results • Entry of tolerances
Edge detector ¹⁾	Automatic point measurement via optical edge detector
Video ¹⁾	<ul style="list-style-type: none"> • Automatic point measurement via video edge detection • Manual autofocus • Show live images • Archiving and output of live images • Zoom and light control, programmable (with the <i>LightZoom</i> versions) • Video connection for digital USB camera (with the <i>Video</i> versions) • Light control over six light sources and zoom control (for version with <i>Video</i> and <i>LightZoom</i>)
CNC ¹⁾	<ul style="list-style-type: none"> • Automation of measurement tasks • Axis control (for XYZQ) for servo and stepper motors • Autofocus via stepper-motor control (Z axis) • CNC outputs and inputs for joystick
3-D profiling¹⁾ (option)	<ul style="list-style-type: none"> • Importing of CAD models • Probing of tested object and comparison with the CAD model • Flexible output of measurement results
Error compensation	<ul style="list-style-type: none"> • Linear, and segmented linear over any number of points • Squareness calibration • Matrix compensation over any number of points
Other connections	<ul style="list-style-type: none"> • Foot switch for two functions
Accessories	Foot switch, fiber-optic cable, holder for fiber-optic cable, calibration standard, demo part, distribution cable
PC interface	PCIe
Operating temperature	0 °C to 55 °C; (storage temperature -30 °C to +70 °C)
Dimensions	241 mm x 126 mm x 22 mm

* Please select when ordering

¹⁾ See the configuration table for possible combinations

²⁾ Depends on the signal period of the connected encoder as well as the subdivision factor

IK 5000 QUADRA-CHEK

Functions

The innovative operator guidance provides self-explanatory information about the various functions. It already supports you while setting up the coordinate system (aligning the part and specifying the datum).

Various predefined features are available for measurement, depending on the version:

2-D measurement: point, line, circle, slot, rectangle

3-D measurement: plane, cylinder, cone, sphere

The "Measure Magic" function makes measurement especially easy by selecting the feature that best matches the distribution of acquired measuring points.

The IK 5000 QUADRA-CHEK enables you to define your own contour features (e.g., a circle exactly defined by its position and dimensions). In addition, you can establish relationships (distances, angles) between features.

Measuring programs that you create yourself or record automatically simplify the work needed for repeated parts. The evaluation electronics graphically take you to the next measuring position during program run.

Depending on the version, the IK 5000 QUADRA-CHEK probes the points of plane contours (2-D) either automatically or manually via crosshairs, optical edge detection, or a video camera.

For 3-D contours such as planes, cylinders, cones, and spheres you can measure points using a triggering touch probe. If a triggering touch probe is used, then the values are transferred automatically. In the case of rigid probing elements, a key must be pressed.

The measured features can be clearly displayed either in three dimensions or in one of the three projection planes.

Multi-sensor scanning

Along with the usual method for measuring point acquisition, the IK 5494 and IK 5594 versions permit multi-sensor scanning; in addition to the video camera, the measuring machine is also equipped with a touch probe. You can then use the touch probe to measure 3-D features on the object and enjoy the advantages of video evaluation for 2-D features. The integrated probe library manages the various measurement tools for you, whether they be optical, video, laser, or touch-probe systems.

Constructed features

QUADRA-CHEK gives you several possibilities for determining dimensions:

- Measuring the features
- Calculating features (e.g., center of a measured circle)
- Relating features to one another (e.g., distance between two circle centers; angle between lines.)

However, you can also construct new features from existing features and from relationships. The properties of these constructed features can then be seen directly in the parts view.

Data management

The integrated data-report generator for customized forms, databases, and tolerance checks is used to archive, export, and import data in numerous formats. You can use the integrated calculation tables for complex, non-standard calculations.

All you need to do is to send your customized reports to a printer or make the data available to other users in a database.

Functional part view window

QUADRA-CHEK provides you with a comprehensive, graphical part view window. You can choose between a 3-D view, or a projection in the XY, YZ, or ZX planes. Additionally, you can magnify, reduce, zoom, shift or rotate the views. You can define tolerances and designed features in any view. The "pass/fail" color coding makes it easy to determine whether the part matches the specifications.

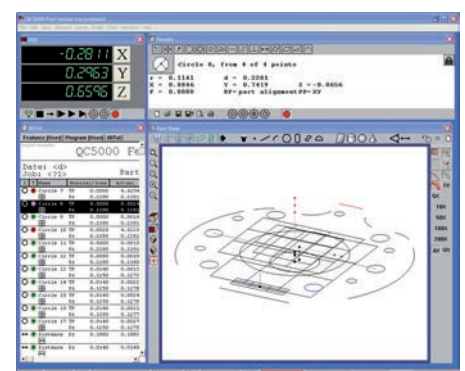
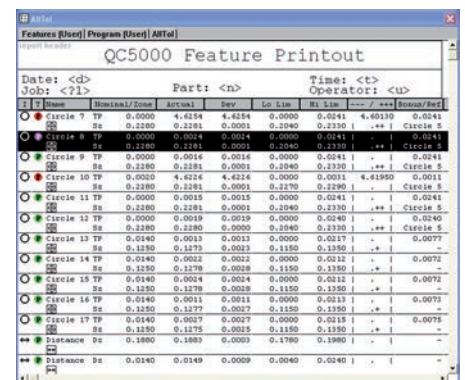
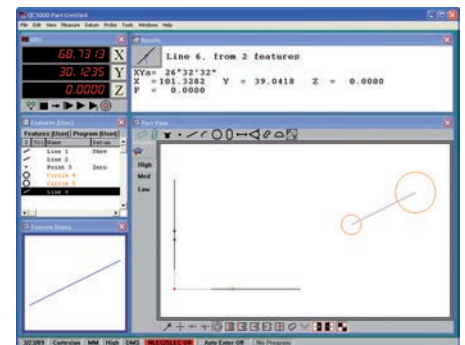
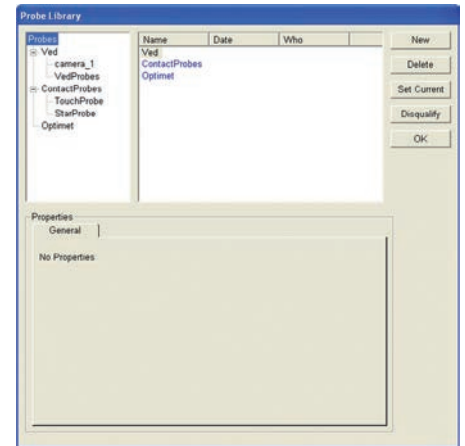

Programming of parts

Difficult and repetitive measuring tasks can be simplified with the aid of a program that you either create yourself or record automatically during measurement of the first part. The QUADRA-CHEK learns the reference points, tolerances, data-output commands, and the sequence of measurements, and then visually guides you to the features to be probed during program execution. The program view also provides you with an optimum overview of the process.

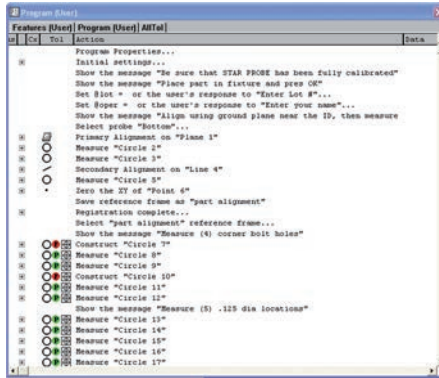

Examples of design capabilities:

2-D possibilities

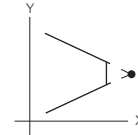

Intersection of two lines

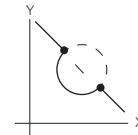

Intersection of line and circle

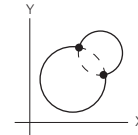

Intersection of two circles

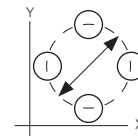

Bolt hole circle formed from three or more circles

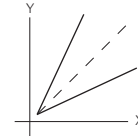

Bisector of two lines

Integrated image processing

In the versions with video functionality, the integrated image editing feature is particularly useful because it displays and saves the video image in real time. QUADRA-CHEK can even assume complete control of the illumination and the motor zoom. A digital USB camera can be connected.

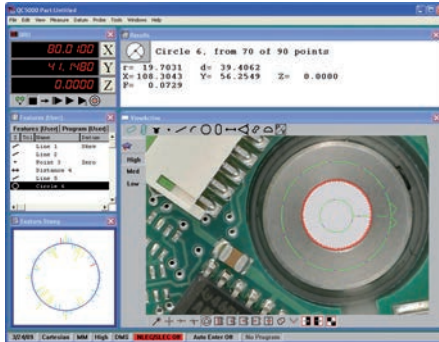

In order to quickly and directly compare the actual status and nominal status, you can import the parts drawing in DXF or IGES format and place it over the video image.

Axis positioning

The CNC versions of the IK 5000 QUADRA-CHEK work as full-fledged controls, directly controlling the positioning of the X, Y, Z, and Q axes. Servo motors or stepper motors can be connected. Amplifiers with two or three axes for stepping motors are available as accessories.

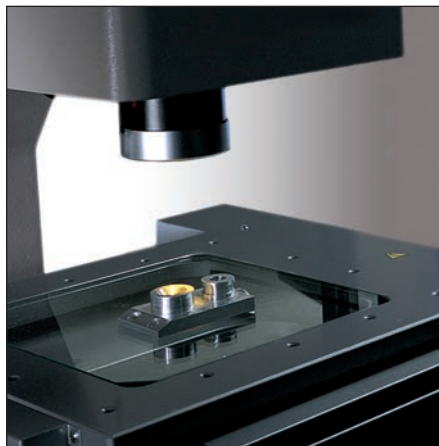

Automating

Programs running in combination with the CNC function of the IK 5000 QUADRA-CHEK run automatically. This minimizes the effects of subjective assessments and increases data throughput noticeably. By automating series of measurements and complex procedures, you spare yourself the strain of performing repetitive measuring tasks.

3-D profiling

The 3-D profiling option simplifies the measurement and evaluation of 3-D contours on multi-sensor and tactile measuring machines as follows: you import the CAD model, measure the real part, and then use the 3-D profiling function to compare the measured points with the CAD model. The measurement results are displayed graphically and can be managed in the usual manner. They can also be transferred to other quality systems.

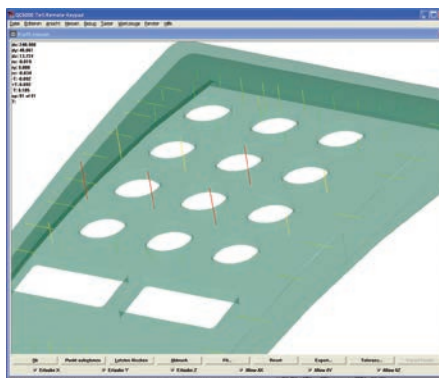

3-D possibilities

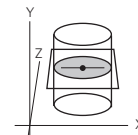

Intersection of cylinder and surface

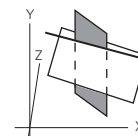

Plane from plane and 3-D line

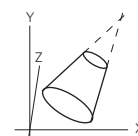

Taper angle

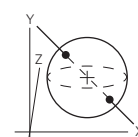

Intersection of sphere and line

ND 287

Evaluation unit for measuring and testing stations

Thanks to its wide range of functions, the ND 287 evaluation unit for a single axis is predestined for measuring and inspection stations, but is also intended for simple positioning tasks. The universal encoder input permits connection of all incremental encoders with 11 μ APP and 1 VPP signals and absolute encoders with the EnDat 2.2 interface from HEIDENHAIN.

Execution

The ND 287 features a sturdy aluminum die-cast housing. A graphic TFT monitor displays the measured values, the status, and the soft-key row. The splash-proof, full-travel keyboard is made to handle the shop floor.

Functions

The ND 287 features numerous functions for measuring and processing individual positions; for example, sorting and tolerance checking mode, minimum/maximum value storage, and measurement series storage. These data make it possible to calculate mean values and standard deviations and display them in histograms or control charts. Thanks to its modular design, the ND 287 permits connection of a second encoder for sum/difference measurement or of an analog sensor (e.g., for temperature compensation). The ND 280 was conceived to perform simple measuring and positioning tasks (see the *Digital Readouts and Linear Encoders for Manually Operated Machine Tools* brochure).

Data interfaces

The ND 287 has serial interfaces for measured value transfer to a PC or printer, for input/output of parameters and compensation value lists, and for diagnostics:

- USB
- RS-232-C/V.24
- Ethernet 100BaseT (option)

The measured value transfer can be started at the ND keyboard via an external command, via the RS-232-C/V.24 software command CTRL+B, or by an adjustable internal clock.

Sorting and tolerance checking

With the sorting function of the ND 287, workpieces can be inspected for dimensional accuracy and divided into classes. The result is indicated in the status display in color or with symbols; in addition, a corresponding signal is available at the switching outputs.

Display freeze

In order to read the display reliably despite rapidly changing values, you can use an external signal to freeze the display. The internal counters keep on running.

Combination with a second encoder

A second encoder or a sensor can be connected to the ND 287 through an optional **encoder module** or **analog module** input assembly. The data from two encoders can be combined through mathematical operands. The result and the two measured values are saved. This permits further areas of application, such as the sum/difference display of two encoders or temperature compensation through a temperature sensor.

Recording and evaluating series of measurements

The ND 287 provides a measured-value memory for recording series of measurements. The measurement value as well as the minimum, maximum, or difference can be displayed during the serial measurements. In addition, the displayed value can be checked for compliance with tolerances by means of the sorting function. The saved measured values are evaluated and represented in the following ways:

- Statistical view (mean value \bar{x} , standard deviation s , and range r)
- Diagram (graphical display of the measured values with minimum/ maximum and mean values as well as tolerance limits)
- Measured value overview as a table

Statistical Process Control (SPC)

For SPC, the ND 287 saves up to 1000 measured values in nonvolatile FIFO memory. They are evaluated with the following functions:

- Statistical view of measured values in the FIFO memory
- Measured value overview as a table
- Diagram of the last 30 measured values
- Histogram in ten classes with probability density function and process capability indexes c_p and c_{pk} .
- Control charts for mean value \bar{x} , standard deviation s , and range r

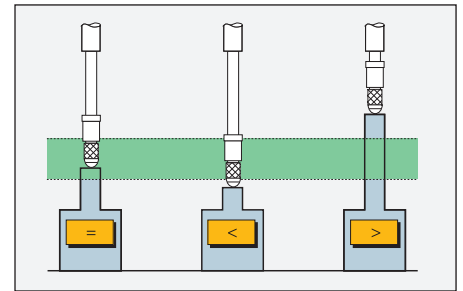

Sorting and tolerance checking

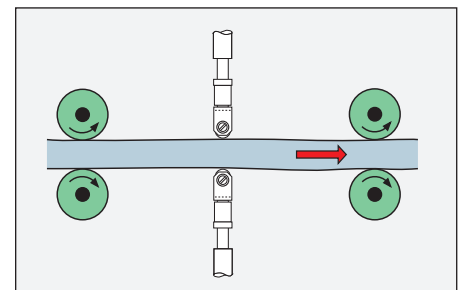

Sum measurement

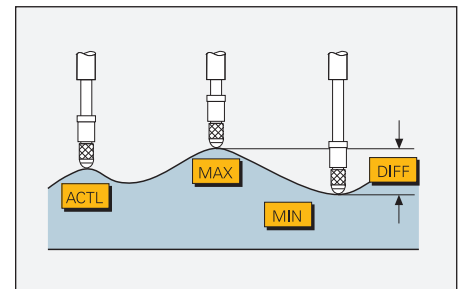

Measured value acquisition

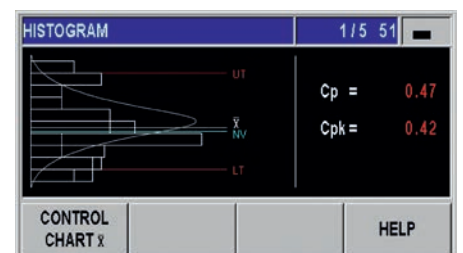



ND 287	
Axes	1; option: second input through encoder module
Encoder inputs Input frequency	$\sim 1 V_{PP}$; $\sim 11 \mu A_{PP}$ or EnDat ¹⁾ (automatic interface detection) $\sim 1 V_{PP}: \leq 500 \text{ kHz}$; $\sim 11 \mu A_{PP}: \leq 100 \text{ kHz}$
Subdivision factor	4096-fold
Display step ²⁾	Adjustable, max. 9 digits <i>Linear axis:</i> 0.5 μm to 0.002 μm ; <i>angular axis:</i> 0.5° to 0.00001° (00° 00' 00.1")
Analog input	Option: $\pm 10 \text{ V}$ through analog module; resolution 5 mV
Display	Screen for position values, dialogs, inputs, graphics functions, and soft keys
Functions	<ul style="list-style-type: none"> • REF reference-mark evaluation for distance-coded or single reference marks • Two reference marks and distance-to-go mode • Remote operation via serial interface • Sorting and tolerance checking • Measurement series with min./max. value storage • Storage of measured values (max. 10 000) • Functions for statistical process control (SPC) • Graphic depiction of distribution/histogram • Sum/difference display (with second encoder module) • Thermal compensation (with analog module)
Axis-error compensation	<i>Linear axis:</i> linear, and segmented linear axis over up to 200 points <i>Angular axis:</i> segmented linear with 180 compensation points (every 2°)
Data interface	RS-232-C/V.24; USB (Type B); option: Ethernet 100BaseT, via Ethernet module
Switching outputs for tasks in automation	<ul style="list-style-type: none"> • Zero crossover; trigger points 1 and 2 • Sorting signals "<" and ">" • Error
Switching inputs for tasks in automation	<ul style="list-style-type: none"> • Zero reset, preset • Cross over reference point and ignore reference signals • Measured value output or display freeze • Start measurement series • Minimum/maximum/difference display • Gating of the two encoder inputs • Sum or difference display • Display measured value 1 or measured value 2
Accessories	Mounting adapter, encoder module, analog module, Ethernet module
Power connection	AC 100 V to 240 V (-15 % to +10 %), 48 Hz to 62 Hz; 30 W
Operating temperature	0 °C to 50 °C; (storage temperature -40 °C to +85 °C)
Protection EN 60529	IP40, front panel IP54
Mass	$\approx 2.5 \text{ kg}$

¹⁾ Purely serial, no evaluation of incremental signals

²⁾ Depends on the signal period of the connected encoder (display step \approx signal periods/4096)

GAGE-CHEK 2000

Evaluation unit for reliable 1-D measured-value acquisition

The GAGE-CHEK 2000 evaluation unit is particularly well suited for positioning tasks on measuring devices and positioning equipment, and for the retrofitting of measuring machines for the capture and transfer of data to a PC.

Design

Thanks to its rugged industrial design, the GAGE-CHEK 2000 is superbly suited for applications in measuring rooms as well as in harsh production environments. Its slim aluminum housing with integrated power adapter and fanless passive cooling system is exceptionally sturdy and resilient. The unit's straightforward touchscreen, made of specially hardened glass, supports multi-touch gesture control and permits operation with gloves.

Functions

The logical arrangement of menus and function elements provides intuitive user guidance that supports you in the use of the various functions. Along with the typical functions of an evaluation unit, such as zeroing and preset setting, the GAGE-CHEK 2000 also offers the following useful features:

- Configurability of each axis for length or angle display
- Measurement series with recording of minimum and maximum values
- Simple switching of the counting direction
- Measured-value output—either manually, continuously, or when triggered by a touch probe

You can transfer the captured measured values to a PC via the data interface.



Software options

Software options allow you to adapt the range of functions of the GAGE-CHEK 2000 to your given requirements. You can enable these software options by entering a license key. Please contact HEIDENHAIN for more information.

Intuitive display

All of the information you need is displayed in a clean and easy-to-read layout on the unit's high-resolution, 7-inch screen. Only those functions that are actually available within a given context and situation are shown. The self-explanatory operating controls provide intuitive user guidance.

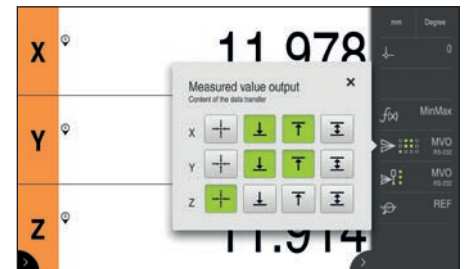



	GAGE-CHEK 2013	GAGE-CHEK 2023	GAGE-CHEK 2093
Axes	3, two of which can be enabled with a software option		
Encoder interface	$\sim 1 V_{PP}$ $\sim 11 \mu A_{PP}$ EnDat 2.2	\square TTL	1 connection: \square TTL 2 connections: $\sim 1 V_{PP}$ $\sim 11 \mu A_{PP}$ EnDat 2.2
Input frequency	$\sim 1 V_{PP}: \leq 400 \text{ kHz}$ $\sim 11 \mu A_{PP}: \leq 150 \text{ kHz}$	$\leq 5 \text{ MHz}$	$\sim 1 V_{PP}: \leq 400 \text{ kHz}$ $\sim 11 \mu A_{PP}: \leq 150 \text{ kHz}$ \square TTL: $\leq 5 \text{ MHz}$
Subdivision factor	4096-fold (only with 1 V _{PP})		
Display step	Configurable for up to eight digits Linear axes X, Y, and Z: down to 0.000 01 mm; rotary axis Q: down to 0.000 01° (00° 00' 00.1'')		
Display	7-inch multi-touch screen (15:9); resolution: WVGA 800 x 480 pixels for dialogs, inputs, position values, and graphics functions		
Functions	<ul style="list-style-type: none"> • Precise capturing of measured values, and spot-on positioning in metrology applications • 100 presets • Measurement series with min. and max. value recording • Recording of the difference between min. and max. values (range) • Manual, continuous, or touch-probe-triggered data transfer • Probing functions (edge, centerline, and circle) • User administration • Configurability of each axis for length or angle display 		
Additional encoder input (software option AEI1)	One additional encoder input		
Error compensation	<ul style="list-style-type: none"> • Linear (LEC) and segmented linear (SLEC) using up to 200 points • Squareness calibration; matrix compensation (NLEC) using up to 99 x 99 points 		
Data interface	1x Ethernet 100 Mbit/1 Gbit (RJ45); 1x Hi-Speed USB 2.0 (Type A)		
Other connections	Foot switch for two functions		
Accessories	Multi-Pos and Duo-Pos stands, Multi-Pos holder, power cable, adapter connector, foot switch		
Power connection	AC 100 V to 240 V ($\pm 10 \%$); 50 Hz to 60 Hz ($\pm 5 \%$); $\leq 38 \text{ W}$		
Operating temperature	0 °C to +45 °C (storage temperature: -20 °C to +70 °C)		
Protection EN 60529	IP65; back panel: IP40		
Mounting	Multi-Pos or Duo-Pos stand; Multi-Pos holder; mounting systems with 50 mm x 50 mm hole pattern		
Mass	Device with Multi-Pos stand: $\approx 2.0 \text{ kg}$; device with Duo-Pos stand: $\approx 1.5 \text{ kg}$; device with Multi-Pos holder: $\approx 1.7 \text{ kg}$; device alone: $\approx 1.3 \text{ kg}$		

GAGE-CHEK 2000

Functions

Configurable function elements

The functionality of the GAGE-CHEK 2000 can be adapted to the given requirements by means of individually configurable function elements in the Inspector view. Along with function elements for the output of measured values, functions such as a preset table and the recording of minimum and maximum values are available as well.

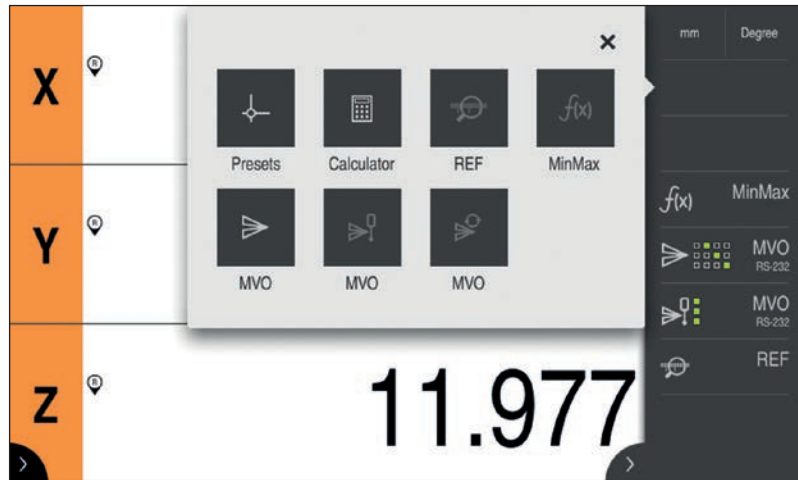

Recording of minimum and maximum values (MinMax)

The GAGE-CHEK 2000 is equipped with a function for recording minimum and maximum values. It can be configured for the axes as desired. The highest and lowest measured values of a measurement series, including their difference, are recorded and can be output over the data interface. This function is particularly advantageous during concentricity testing.



Touch-probe connection

The GAGE-CHEK 2000 is equipped with a connection for touch probes (e.g., from HEIDENHAIN or Renishaw). During probing, the evaluation unit automatically displays the current position value, taking the radius of the stylus into account.



Configurable data formats for measured-value output

In addition to providing a default format, the GAGE-CHEK 2000 also features the option of storing your own data formats for data transfer. Thanks to this configurability of data formats, the GAGE-CHEK 2000 is particularly effective as a data logger for the retrofitting of manually operated measuring machines. Within such applications, the GAGE-CHEK 2000 captures the measured values and relays them to a higher-level PC for processing.

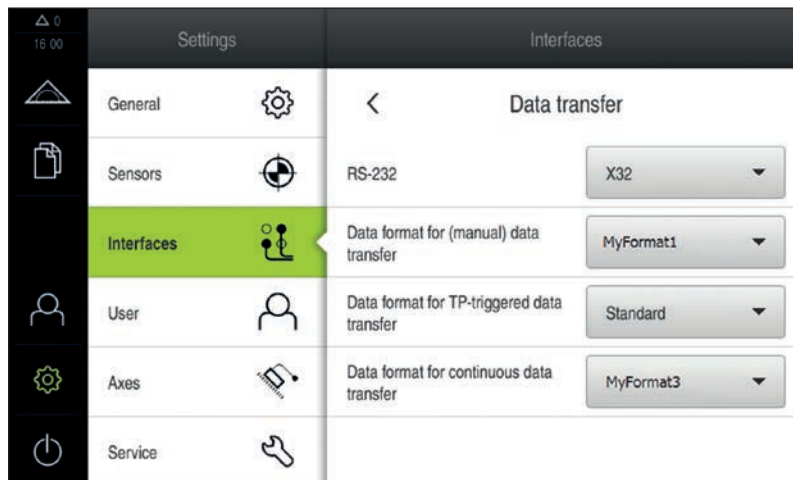

ND 2100G GAGE-CHEK

Evaluation unit for multipoint inspection apparatuses

The ND 2100G GAGE-CHEKs are versatile metrology displays for measuring and inspection tasks in manufacturing and quality assurance. With inputs for up to eight encoders, they are predestined for multipoint measurements from simple pass/fail detection up to complex SPC evaluation.

Execution

The ND 2100G evaluation units have a robust, die-cast aluminum enclosure and a keyboard suited to their environment. A screen displays the measured values, the soft-key row, and other information.

Functions

The inputs can be assigned and combined as desired with mathematical, trigonometric, or statistical formulas. This makes it possible to measure even complex dimensions such as thickness, flatness, volume, and more. The results are displayed numerically or graphically as a color bar graph or a dial, or archived for statistical process control (SPC). The GAGE-CHEK can be configured for basic or advanced applications. Soft keys and hot keys can be adapted as required. The minimum/maximum function of the ND 2100G evaluation unit monitors and stores the highest and lowest measured or calculated value. Warning and tolerance limits can be assigned to each display value. Results outside of the tolerance are marked with a different color. An acoustic alarm sounds simultaneously. Tolerance values, SPC parameters, and custom formulas are stored for individual parts. GAGE-CHEK can thus manage up to 100 parts with up to 16 visible and 16 invisible measurands. The rapid acquisition of measurement data enables the monitoring of dynamic events, such as the eccentricity of a rotating shaft.

Data interfaces

The GAGE-CHEK features various interfaces for communicating with parent systems:

- RS-232-CV.24 for PCs and for remote operation of the GAGE-CHEK
- USB

A list of possible printers is available on the Internet at www.heidenhain.de.

DRO view

The display values appear in large, easy-to-read numbers. Values outside the tolerance are color-coded, immediately notifying you of errors.

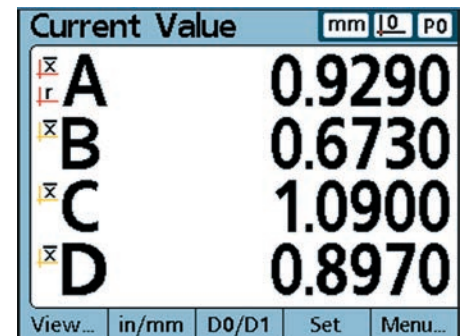

Bar diagram

You can select to have the values shown as a color-enhanced vertical or horizontal bar graph. The defined warning limits and tolerance limits provide instant feedback. If these limits are exceeded, the color of a bar changes from green to yellow or red, thereby alerting you to critical dimensions.

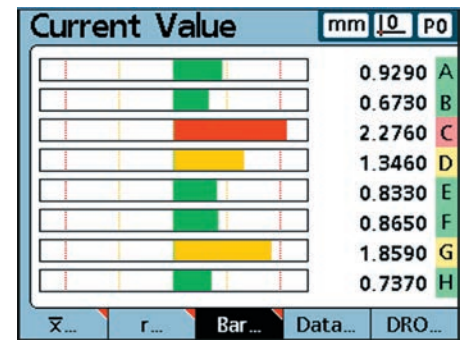

SPC and data storage

GAGE-CHEK includes integrated SPC functions such as mean value charts (X bar) and range charts (R). Min, max, sigma, cp, and cpk are also calculated, and are clearly displayed as a graph or histogram. Historical raw data can be saved in a tabular numeric display. Each dimension and all data are time- and date-stamped.

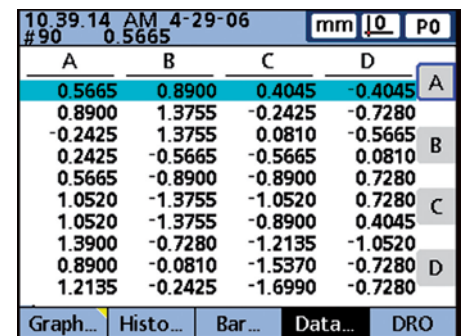

Formulas and combinations

You can use mathematical and trigonometric formulas, as well as logical conditions, to combine individual measured values or measurement sequences with each other, and so create complex calculations. This can be used, for example, to calculate and display the circumference of a turned part, the volume of a cube, or the angle between two cams, as well as to assign tolerance limits to these values.

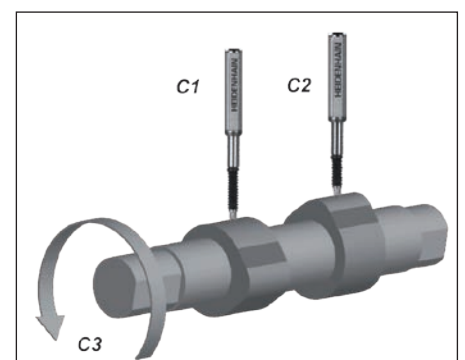



	ND 2104 G	ND 2108 G
Axes	4	8
Encoder inputs* Input frequency	$\sim 1 V_{PP}$ \square TTL or EnDat 2.2 (other interfaces upon request) $\sim 1 V_{PP}: \leq 275 \text{ kHz}$; \square TTL: $\leq 3 \text{ MHz}$	
Subdivision factor	10-fold (only for 1 V _{PP})	
Display step ¹⁾	Adjustable, max. 7 digits <i>Linear axis:</i> 1 mm to 0.00001 mm <i>Angular axis:</i> 1° bis 0,0001° (00° 00' 01")	
Display	5.7-inch screen for position values, dialogs, inputs, graphics functions, and soft keys	
Functions	<ul style="list-style-type: none"> • Part programming for up to 100 parts • Graphical display of measurement results • Sorting and tolerance checking using tolerance and warning limits, with display as a bar graph • Measurement series with min./max. value storage • Mathematical and trigonometric formulas • Functions for statistical process control (SPC) • Graphical display of measurement results and distribution • Data storage of values and formulas • Convenient diagnostics of the connected encoders (only EnDat 2.2) 	
Error compensation	Linear, and segmented linear over up to 60 points	
Data interface	<ul style="list-style-type: none"> • RS-232-C/V.24 • USB (type A) 	
Switching inputs	5 TTL inputs (freely definable)	
Switching outputs	12 TTL outputs (freely definable) 2 relay outputs	
Other connections	Foot switch for two functions, keypad	
Accessories	Foot switch, remote keypad, protective cover, tilting base, mounting adapter	
Power connection	AC 100 V to 240 V (–15 % to +10 %), 47 Hz to 63 Hz; $\leq 100 \text{ W}$	
Operating temperature	0 °C to 45 °C; (storage temperature –20 °C to +70 °C)	
Protection EN 60529	IP40	
Mounting*	Tilting base or mounting base	
Mass	<i>ND with tilting base:</i> $\approx 4.8 \text{ kg}$; <i>ND with mounting adapter:</i> $\approx 2 \text{ kg}$	

* Please select when ordering

¹⁾ Depends on the signal period of the connected encoder as well as the subdivision factor

EIB 700

Evaluation unit with measured-value memory

The EIB 700 evaluation units feature connections for four axes. They are especially well suited for precise position measurement in inspection stations and multipoint inspection apparatuses as well as for mobile data acquisition, such as in machine calibration.

The EIB 700 series is ideal for applications requiring high-resolution encoder signals and fast measured-value acquisition. Ethernet transmission also enables you to use switches or hubs for connecting more than one EIB. It is also possible to use WLAN transmission, for example.

Execution

The EIB 700 features a bench-top housing. With an accessory mounting bracket it can also be easily built into a 19-inch housing. It is designed for the following voltage supplies:

EIB 741: AC 100 V to 240 V

EIB 742: DC 24 V

Functions

The EIB 700 subdivides the periods of the incremental signals up to 4096-fold for **measured-value generation**. The deviations within one signal period are automatically reduced by adjustment of the sinusoidal incremental signals.

The integrated **measured-value memory** enables the EIB 700 series to save typically 250000 measured values per axis. Internal or external triggers can be used for axis-specific storage of the measured values.

The **interval counter** permits position-dependent triggering in connection with an incremental encoder on axis 1. In addition, the signals of axis 1 are interpolated and forwarded to a position counter. Triggering pulses are generated either at a certain position or equidistantly in adjustable intervals. They begin after an adjustable start position has been traversed and continue in both counting directions. The trigger pulses can be used for triggering further EIB internal axes or also over a trigger output.

Data interface

A standard Ethernet interface using TCP/IP or UDP communication is available for **data output**. This permits direct connection to a PC, laptop, or industrial PC. The type of measured-value transfer can be selected through the operating mode (transfer of individual values, block transfer, or transfer upon software request).

Driver software for Windows, Linux, and LabVIEW as well as example programs and the EIB application software are included in the items supplied, in order to **process the measured values** on the PC. The driver software enables customers to easily program their own applications. In addition, example programs demonstrate the capabilities of the EIB 700 series. The EIB application software is for commissioning and for demonstrating the capabilities of the EIB 700 series. This software is made available as source code and can serve as a platform for the development of one's own applications.

Operating modes	Soft Real-Time	Recording	Streaming	Polling
Properties	Immediate transmission of measured values when the trigger event occurs	Storage of measured values in the EIB's internal measured-value memory	Buffering and block transfer of measured values	Software request from customer application
Selectable trigger sources	All internal and external sources			By software command
Trigger rate	≤ 10 kHz (access time to position values < 100 μs)	≤ 50 kHz	≤ 50 kHz Max. 1 200 000 bytes/s	Depends on the application
Typical applications	Closed-loop control	Very high recording rate Offline analysis of data	High recording rate in combination with high recording depth	Quasi-static measured value recording



Specifications	EIB 741 EIB 742		
Encoder inputs	D-sub connections: 15-pin, female (X11 to X14), for four encoders		
Interface (switchable)	$\sim 1 V_{PP} \sim 11 \mu A_{PP}$	EnDat 2.1	EnDat 2.2
Voltage supply for encoders	DC 5.12 V ± 0.15 V; max. 450 mA per channel Overcurrent protection (automatic switch-off, resettable) at 550 mA		
Input frequency	≤ 500 kHz	–	–
Subdivision factor	4096-fold	–	–
Signal adjustment	Automatic adjustment of offset, phase, and amplitude	–	–
Cable length ¹⁾	≤ 150 m	≤ 150 m	≤ 100 m
Data register for measured values	48 bits (only 44 bits are used)		
Interval counter	Derived from axis 1 (only 1 V_{PP}) ⁴⁾ , Interpolation factor can be set from 1-fold to 100-fold Can be used as trigger source or additional counting axis	–	–
Measured-value memory	Typically 250 000 position values per channel		
Measured-value trigger²⁾	Storage of the measured values of the four axes alternatively through external or internal trigger. External: <ul style="list-style-type: none"> • Signal via trigger input • Software command (over Ethernet) Internal: <ul style="list-style-type: none"> • Timer and interval counter • Reference pulse of the respective axis (from axis 1 also possible for other axes) 		
Trigger input ³⁾	D-sub connection: 9-pin, male; differential inputs as per RS-485 (terminating resistors can be activated)		
Trigger output ³⁾	D-sub connection: 9-pin, female; four differential outputs as per RS-485		
Access to measured values	Depends on the selected operating mode (see separate table)		
Software	<ul style="list-style-type: none"> • Driver software for Windows, Linux, and LabVIEW • Program examples • EIB application software 		
Data interface⁵⁾	Ethernet as per IEEE 802.3 (10/100/1000 Mbit/s)		
Network address	Automatic assignment through Dynamic Host Configuration Protocol (DHCP) or manual assignment		
Dimensions	≈ 213 mm x 152 mm x 42 mm		
Operating temperature	0 °C to 45 °C; (storage temperature 0 °C to +70 °C)		
Power supply	EIB 741: AC 100 V to 240 V (± 10 %), 50 Hz to 60 Hz (± 2 %), power consumption up to 30 W EIB 742: DC 24 V (-15 %/+20 %), max. 2 A		

¹⁾ The supply voltage range of the encoder must be maintained; specified cable length applies when HEIDENHAIN cables are used.

²⁾ Various trigger sources can be assigned to the individual axes.

³⁾ Can also be used as logical input or output; ⁴⁾ Maximum input frequency for referencing: 70 kHz

⁵⁾ The quality of the data cable between EIB and PC must be adapted to the transmission rate and cable length.

IK 220

Evaluation unit as a PC solution

The IK 220 evaluation unit is a PC counter card for two axes. It is inserted directly into a vacant PCI slot in the computer. The IK 220 is ideal for applications in which the measured values are to be evaluated directly in the PC.

Design

Two HEIDENHAIN encoders with sinusoidal current signal ($\sim 11 \mu\text{A}_{PP}$), sinusoidal voltage signal ($\sim 1 \text{V}_{PP}$), or EnDat 2.1 or SSI interface can be connected to the IK 220. External latch inputs/outputs and the output of ($\sim 11 \mu\text{A}_{PP}$) measured value signals can be implemented by using additional slot covers (accessory).

Functions

The IK 220 subdivides the periods of sinusoidal encoder signals up to 4096-fold for measured-value generation. They are called and stored either by using external latch inputs or by software.

The IK 220 features an integrated **measured value memory**. A total of up to 8192 measured values can be stored in the buffer and downloaded in a single block.

The **measured values are further processed** in the PC by programs created by the operator. Examples of such programs and driver software for Windows 2000/XP/Vista/7 (32/64 bit) are supplied with the IK card to demonstrate the PC counter card's capabilities.

Basic circuit diagram

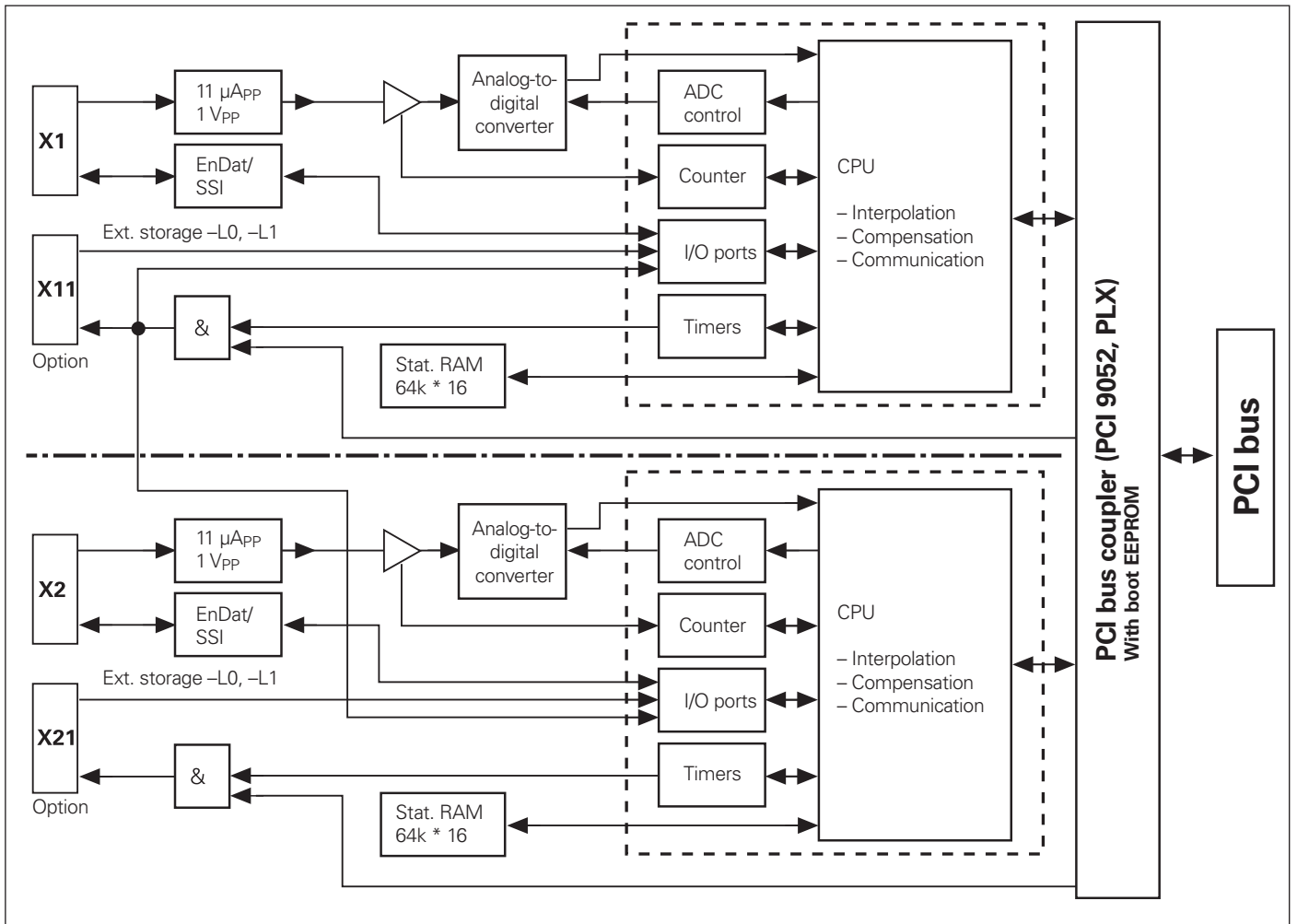

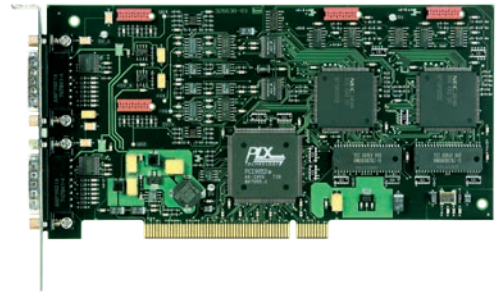

IK 220					
Encoder inputs	D-sub connections: 15-pin, male (X1 and X2), for two encoders				
Input signals (switchable)	<table border="1" style="width: 100%; border-collapse: collapse;"> <tr> <td style="width: 25%; text-align: center;">$\sim 1 V_{PP}$</td> <td style="width: 25%; text-align: center;">$\sim 11 \mu A_{PP}$</td> <td style="width: 25%; text-align: center;">EnDat 2.1</td> <td style="width: 25%; text-align: center;">SSI</td> </tr> </table>	$\sim 1 V_{PP}$	$\sim 11 \mu A_{PP}$	EnDat 2.1	SSI
$\sim 1 V_{PP}$	$\sim 11 \mu A_{PP}$	EnDat 2.1	SSI		
Input frequency	<table border="1" style="width: 100%; border-collapse: collapse;"> <tr> <td style="width: 25%; text-align: center;">$\leq 500 \text{ kHz}$</td> <td style="width: 25%; text-align: center;">$\leq 33 \text{ kHz}$</td> <td style="width: 25%; text-align: center;">–</td> <td style="width: 25%;"></td> </tr> </table>	$\leq 500 \text{ kHz}$	$\leq 33 \text{ kHz}$	–	
$\leq 500 \text{ kHz}$	$\leq 33 \text{ kHz}$	–			
Cable length ¹⁾	<table border="1" style="width: 100%; border-collapse: collapse;"> <tr> <td style="width: 25%; text-align: center;">$\leq 60 \text{ m}$</td> <td style="width: 25%;"></td> <td style="width: 25%; text-align: center;">$\leq 10 \text{ m}$</td> <td style="width: 25%;"></td> </tr> </table>	$\leq 60 \text{ m}$		$\leq 10 \text{ m}$	
$\leq 60 \text{ m}$		$\leq 10 \text{ m}$			
Adjustment of encoder signals	Offset, phase, and amplitude are adjusted through software				
Signal subdivision	4096-fold				
Data register for measured values	48 bits; only 44 bits are used for the measured value				
Internal memory	For 8192 position values				
Measured-value trigger	<p>Alternatively through</p> <ul style="list-style-type: none"> • External latch signals (over separate IK assembly for external inputs/outputs) • Software command • Timer • Traversing the reference marks 				
Access time to measured values	<table border="1" style="width: 100%; border-collapse: collapse;"> <tr> <td style="width: 50%; vertical-align: top;"> <ul style="list-style-type: none"> • <i>Without adjustment, without compensation run:</i> $\leq 100 \mu s$ • <i>With adjustment, without compensation run:</i> $\leq 110 \mu s$ • <i>With adjustment, with compensation run:</i> $\leq 160 \mu s$ </td> <td style="width: 50%; vertical-align: top;">Depends on the encoder</td> </tr> </table>	<ul style="list-style-type: none"> • <i>Without adjustment, without compensation run:</i> $\leq 100 \mu s$ • <i>With adjustment, without compensation run:</i> $\leq 110 \mu s$ • <i>With adjustment, with compensation run:</i> $\leq 160 \mu s$ 	Depends on the encoder		
<ul style="list-style-type: none"> • <i>Without adjustment, without compensation run:</i> $\leq 100 \mu s$ • <i>With adjustment, without compensation run:</i> $\leq 110 \mu s$ • <i>With adjustment, with compensation run:</i> $\leq 160 \mu s$ 	Depends on the encoder				
Interface	PCI bus (plug and play) Local Bus Specification Rev. 2.1				
Driver software and demonstration program	For Windows 2000/XP/Vista/7 (32- and 64-bit) in VISUAL C++, VISUAL BASIC and BORLAND DELPHI				
Encoder outputs	<p>$\sim 11 \mu A_{PP}$</p> <p>Over PCB connector on the IK (10-pin, female)</p> <p>Fitting cable assembly with PC-slot cover available as option</p>				
Power consumption	$\approx 4 \text{ W}$, without encoders				
Dimensions	190 mm x 100 mm				
Operating temperature	0 °C to 55 °C; (storage temperature –30 °C to +70 °C)				

¹⁾ With HEIDENHAIN cable; larger cable lengths upon request

Mounting

Mounting the ND 200

ND 200 series

The ND 200 series digital readouts were conceived as bench-top units. They can easily be stacked. Recesses on the top prevent the stacked units from moving out of place.

You can secure the ND 28x from below by using M4 screws on a base plate.

Two ND 28x readouts fit next to each other in a 19-inch housing. A mounting adapter is available as an accessory for mounting in a 19-inch housing.

Accessories

Mounting adapter for 19-inch housing
ID 654020-01



ND 287

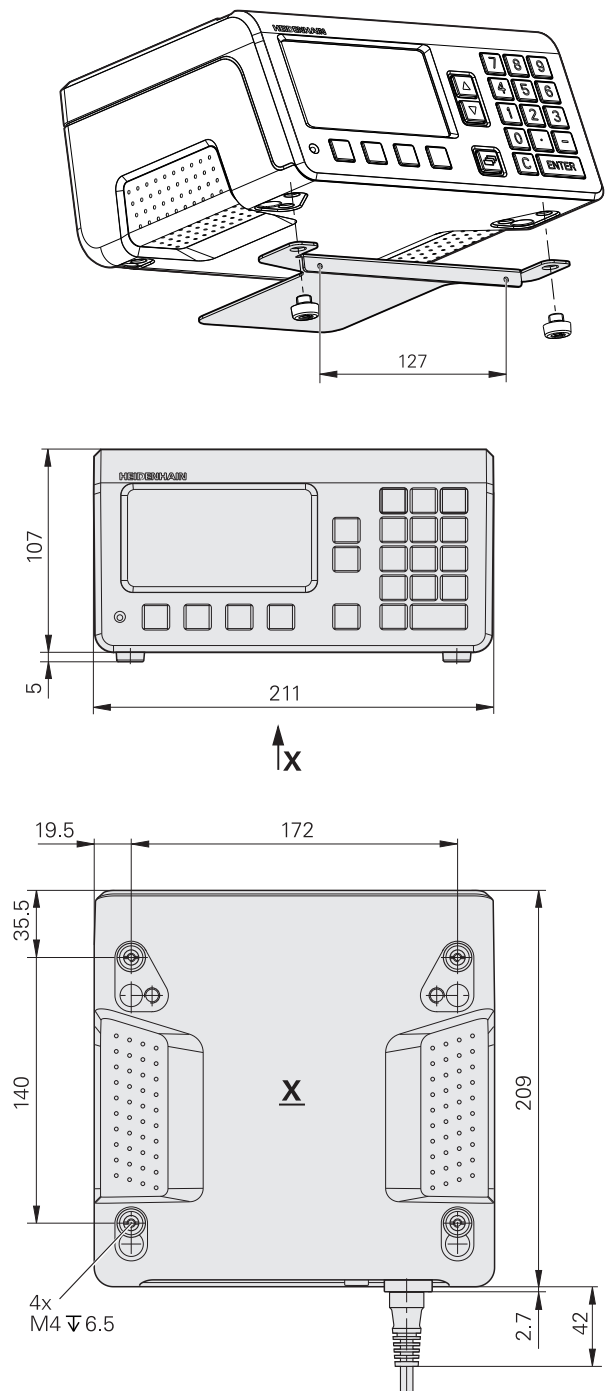

Mounting the EIB 700

The EIB 700s were conceived as bench-top units. They must be installed in a well-ventilated area. The operating orientation is specified.

You can secure the EIB 700 from below by using M4 screws on a base plate. Two EIB 700 units fit next to each other in a 19-inch housing. They occupy one height unit. A mounting bracket is available as an accessory.



Accessories

Mounting bracket

For installation of two EIB 74x in a 19-inch housing
ID 671144-01

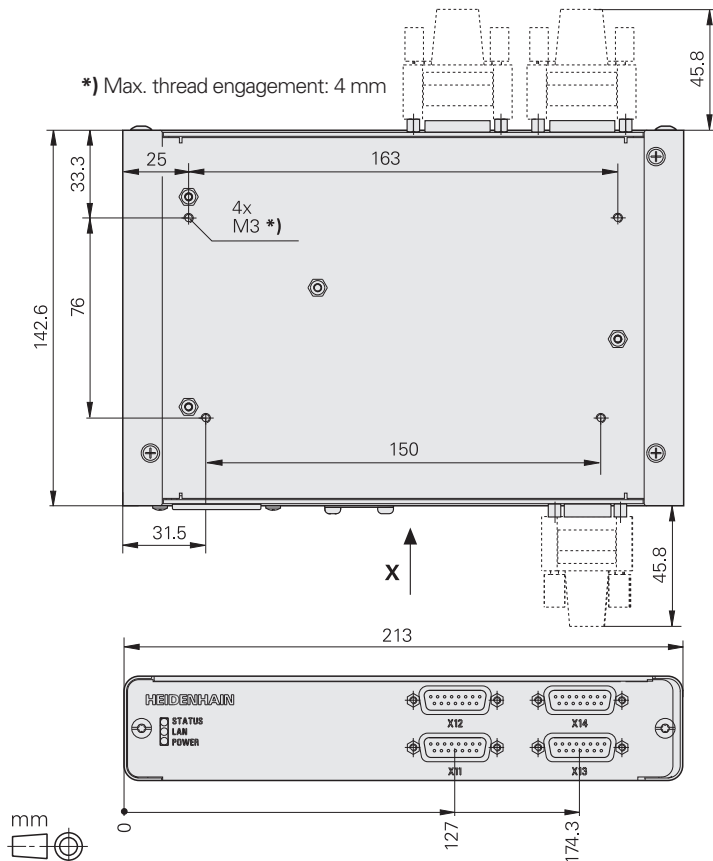
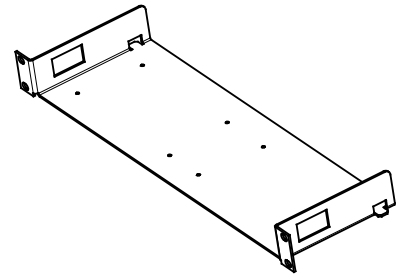

mm
Tolerancing ISO 8015
ISO 2768 - m H
≤ 6 mm: ±0.2 mm

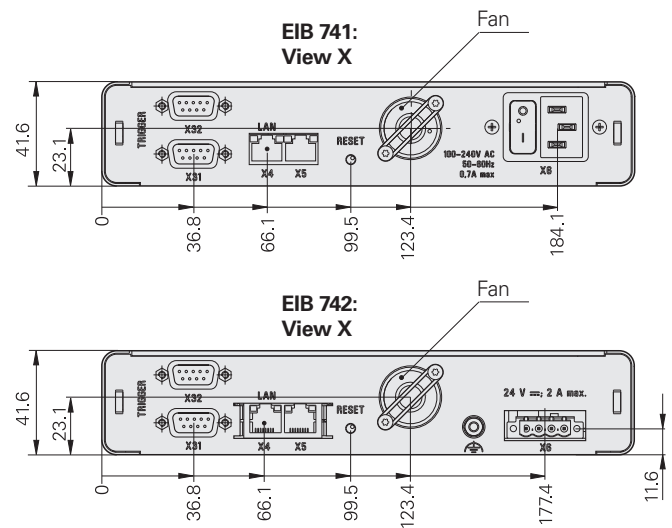

Mounting the ND 2000

The ND 2000 is shipped with either a tilting base or a mounting adapter.

Tilting base

The readout can be used as a tabletop unit when placed on the tilting base. The readout can then be tilted forward or backward by up to 20° for the best reading angle. The tilting base can be attached with M5 screws.

ID 382892-02

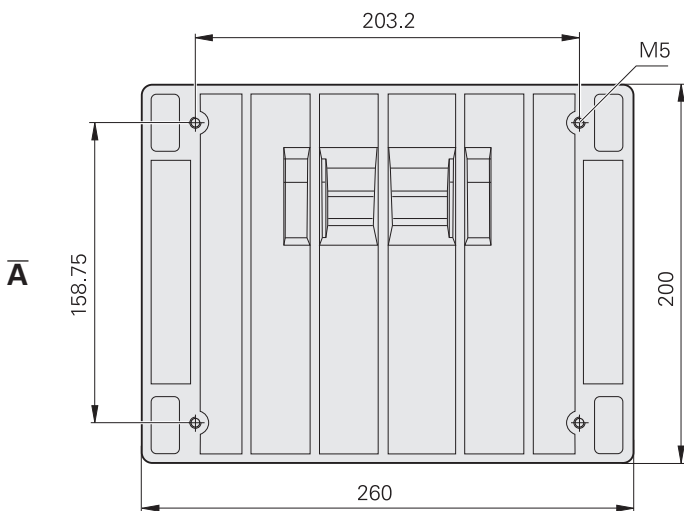
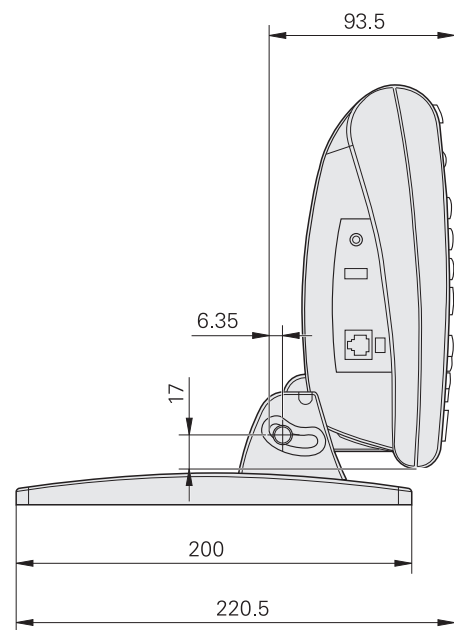
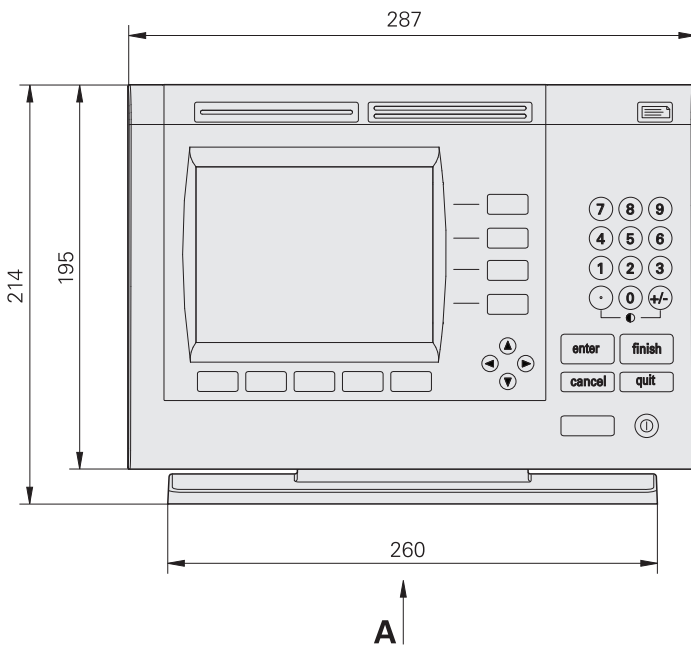

mm

 Tolerancing ISO 8015
 ISO 2768 - m H
 ≤ 6 mm: ±0.2 mm

Mounting adapter

The mounting adapter is used to attach the ND 2000 to a mounting arm or directly to the machine. It also enables the user to tilt the readout.

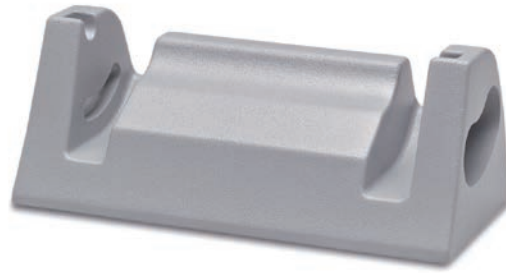
ID 682419-01



Mounting adapter

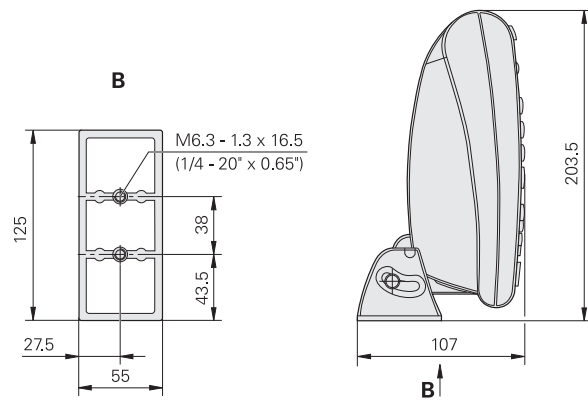

Accessories

Protective cover

Protective covers are accessories for protecting the keyboard and screen of the ND 2000 from becoming soiled. The display can still be easily read through the transparent protective covers. They fit themselves optimally to the front of the unit, without impairing the ease of operation.

ND 21xx

ID 681051-03



Mounting the QUADRA-CHEK 2000 and GAGE-CHEK 2000

The QUADRA-CHEK 2000 and the GAGE-CHEK 2000 can be mounted flexibly at various angles by means of the Multi-Pos or Duo-Pos stand. For fastening to a machine, the Multi-Pos holder is well suited, as are mounting systems with a 50 mm x 50 mm hole pattern.

Multi-Pos stand

For setup on and fastening to a horizontal surface; continuous tilt range of 90°

ID 1089230-07



**QUADRA-CHEK 2000
with Multi-Pos stand**

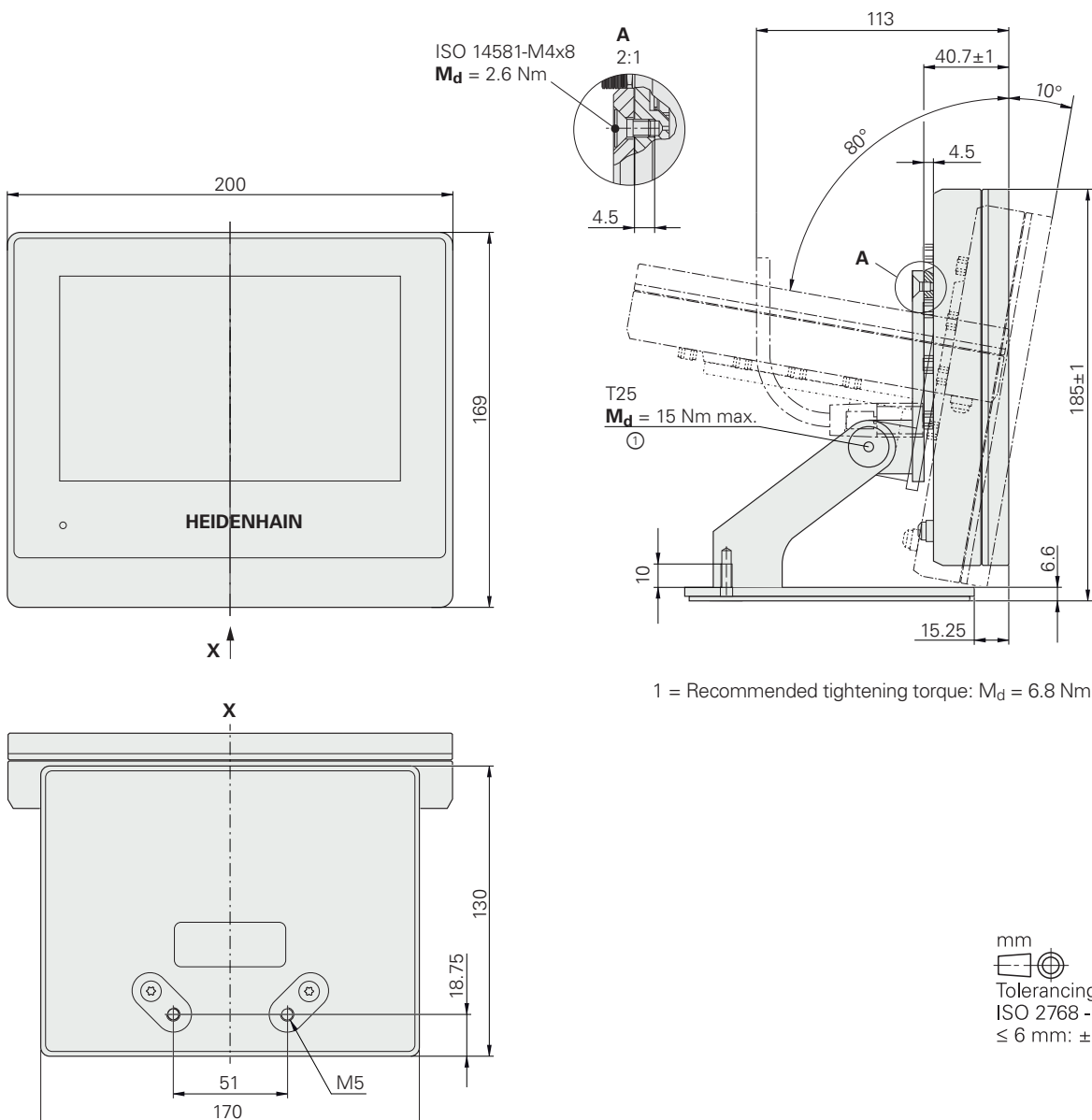

mm

 Tolerancing ISO 8015
 ISO 2768 - m H
 ≤ 6 mm: ±0.2 mm

Duo-Pos stand

For setup on and fastening to a horizontal surface; possible tilt angles: 20° or 45°

ID 1089230-06

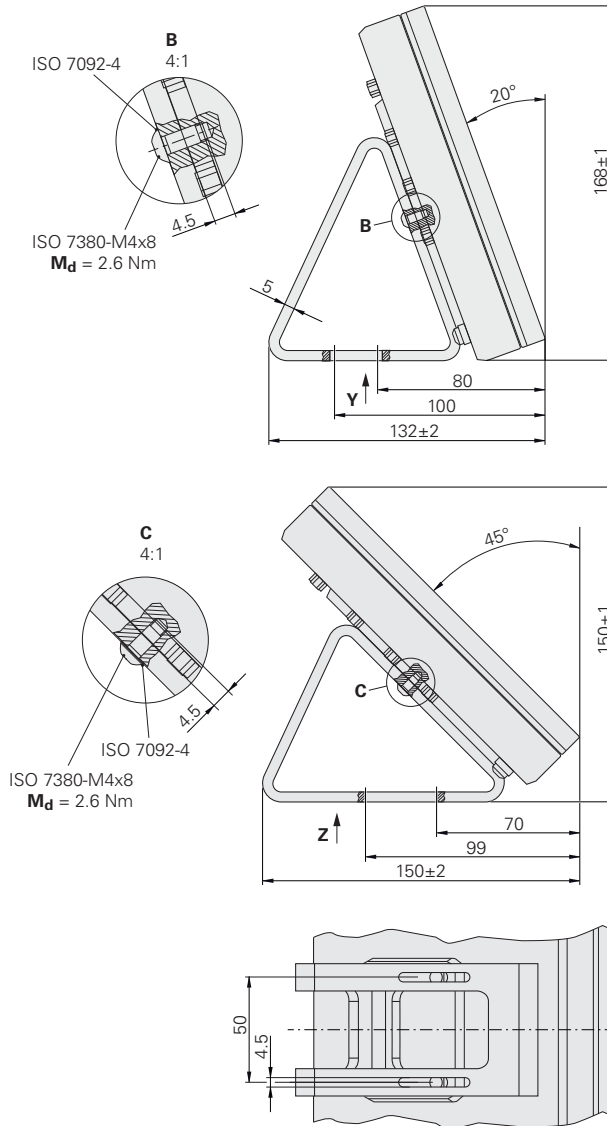

Multi-Pos holder

For fastening to an arm; continuous tilt range of 90°

ID 1089230-08

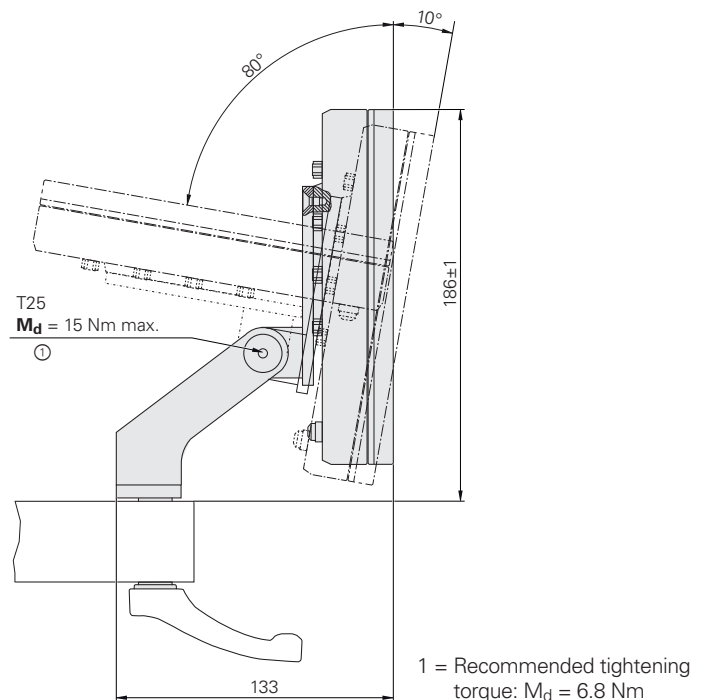

Mounting the QUADRA-CHEK 3000

The QUADRA-CHEK 3000 can be mounted flexibly with the Multi-Pos or Duo-Pos stand at various tilting angles. The Multi-Pos holder or other fastening systems compatible with VESA MIS-D 100 are suitable for fastening it to a machine.

Multi-Pos stand

For setup on and fastening to a horizontal surface; continuous tilt range of 90°

ID 1089230-03



**QUADRA-CHEK 3000
with Multi-Pos stand**

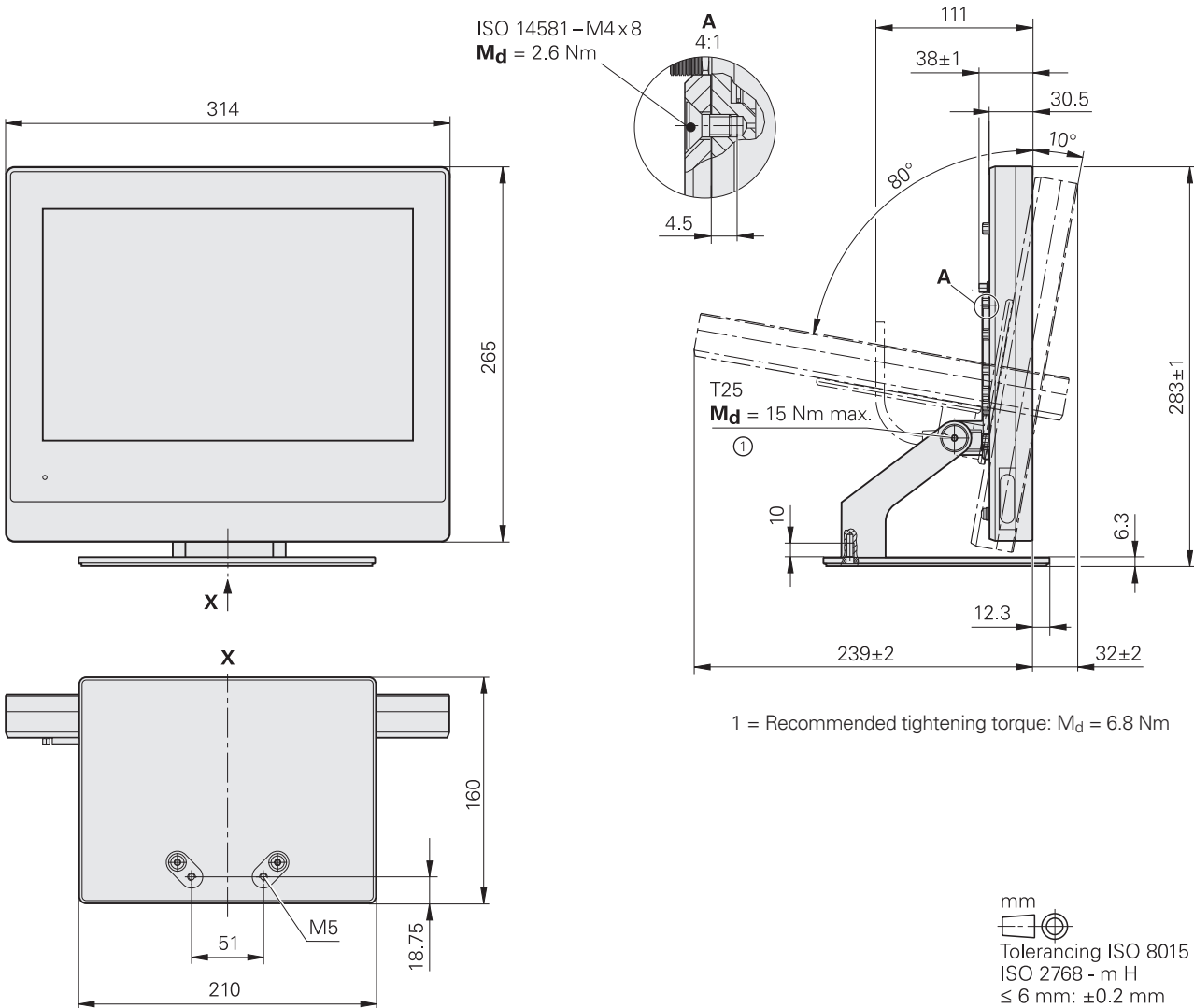

Duo-Pos stand

For setup on and fastening to a horizontal surface; possible tilt angles: 20° or 45°

ID 1089230-02

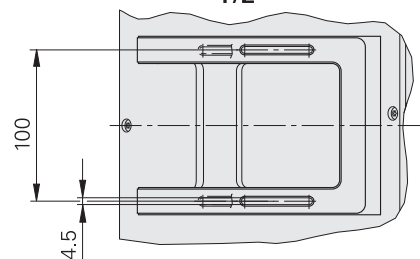
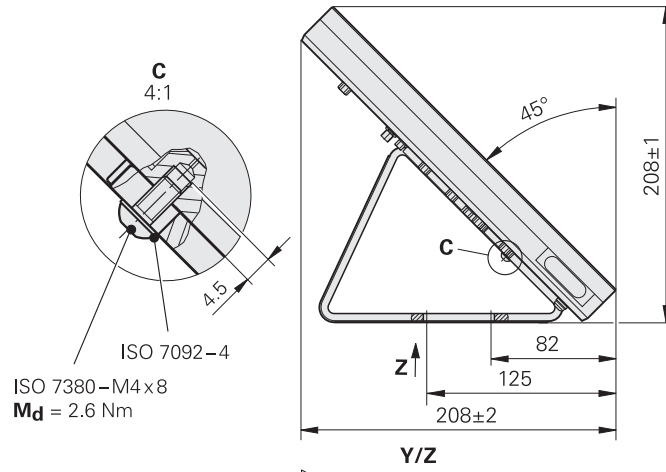
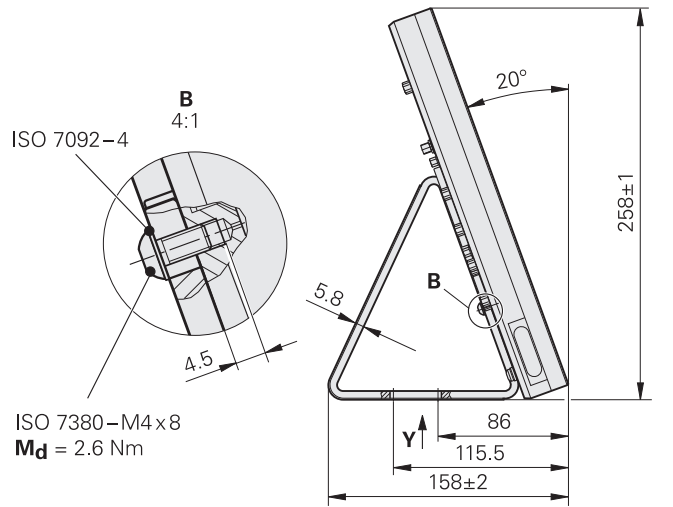

Multi-Pos holder

For fastening to an arm; continuous tilt range of 90°

ID 1089230-04

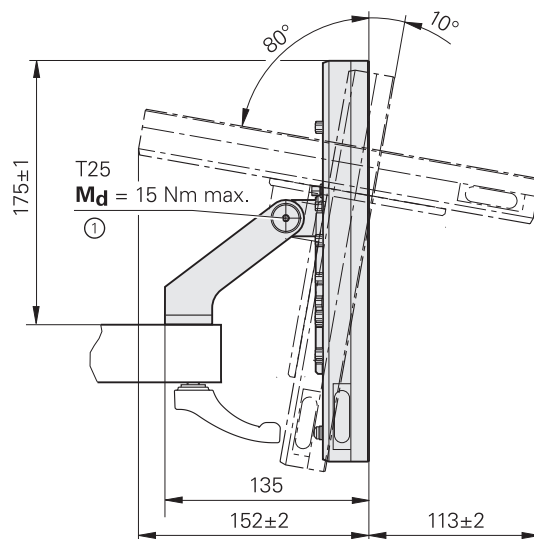

1 = Recommended tightening torque: $M_d = 6.8 \text{ Nm}$

Optional accessories

Adapter connectors and calibration/demo parts

Calibration standard

For the calibration of video measuring machines, measuring microscopes, and profile projectors. It can be traced back to national or international standards.
ID 681047-01



Calibration standard

2-D demo part

The 2-D demo part is included with the QUADRA-CHEK 2000, QUADRA-CHEK 3000, and IK 5000. The application examples in the operating instructions are based on this part. It can be reordered if a replacement is necessary.
ID 681047-02



2-D demo part

3-D demo part (accessory)

Demo part for touch-probe applications. The examples in the operating instructions for the QUADRA-CHEK 3000 and IK 5000 are based on this part.
ID 681048-01

3-D demo part for multi-sensor scanning (accessory)

Demo part for combined touch-probe applications and video edge detection. It is used for the examples in the IK 5000 User's Manual.
ID 681048-02



3-D demo part

Adapter connectors for QUADRA-CHEK 2000, QUADRA-CHEK 3000, and GAGE-CHEK 2000

For conversion of the pin layout from HEIDENHAIN TTL to RSF and Renishaw TTL.
ID 1089210-01

For conversion between different pin layouts for HEIDENHAIN 11 μ APP.
ID 1089213-01

For conversion between different pin layouts for HEIDENHAIN 1 VPP.
ID 1089214-01

For conversion of the pin layout from HEIDENHAIN 1 VPP to Mitutoyo 2 VPP.
ID 1089216-01

Adapter connector for QUADRA-CHEK 3000

For conversion of the pin layout for light control (without zoom) from QUADRA-CHEK 3000 (X103) to assignment for ND 1300 QUADRA-CHEK (light)
ID 1089212-01



3-D demo part for multi-sensor scanning

Adapter cables for QUADRA-CHEK 3000 and QUADRA-CHEK 2000

For conversion of the pin layout from HEIDENHAIN touch-probe interface to Renishaw touch-probe interface
ID 1095709-xx



Adapter connector for TTL

Adapter connector 11 μ APP, 1 VPP, 2 VPP

Adapter connector for light control

External control elements

The evaluation electronics and the PC package can be operated easily and intuitively. Nevertheless, remote operability may also be useful and convenient in some situations. The following components are available for remote operation:

Foot switch (accessory)

Cable length 2.4 m

For ND with RJ45 connector
with two freely assignable keys
ID 681041-01

For IK 5000 with 3-pin DIN connector
with two freely assignable keys
ID 681041-02

For QUADRA-CHEK 2000 and
GAGE-CHEK 2000
with 15-pin D-sub connector
with two keys
ID 681041-04

Keypad (accessory)

For remote operation of the ND 2000 evaluation unit; features a numeric keypad and "enter" and "finish" keys; cable length: 4.5 m; with RJ45 connector.

ID 681043-01

Joystick (accessory)

For remote operation and sensitive traversing of axes for IK 5000. With 15-pin D-sub connector.

Without trackball	ID 681044-02
With trackball	ID 681044-01
With trackball and Z-focus fine adjustment	ID 681044-05



Foot switch



Keypad



Joystick without trackball



Joystick with trackball and Z-focus fine adjustment

Optical edge detector

Optical edge detector*

Two fiber-optic cables are necessary for edge detection with an optical edge detector. One fiber-optic cable is attached to the projection screen with a transparent holder. The second cable is attached near the transmitted light source so that the fibers point toward the light source. The following accessory components are required.

* Only required for the OED software option

Fiber-optic cable (accessory)

With one right-angle end and an SMA connector (subminiature A) for QUADRA-CHEK and IK.
Bend radius ≥ 25 mm
Temperature ≤ 100 °C
Lengths 2 m, 3 m, 5 m

ID 681049-xx

Holder (accessory)

With a hole for accepting the right-angle end of fiber-optic cables. Transparent design so that it can be attached to the projection screen.
Lengths: 350 mm, 600 mm, 760 mm

ID 681050-xx

Fiber-optic cable connector (accessory)

Two SMA (subminiature A) connectors for connecting an integrated edge detector.
Bend radius ≥ 25 mm
Temperature ≤ 100 °C
Lengths 2 m, 3 m, 5 m

ID 681049-xx



Fiber-optic cable

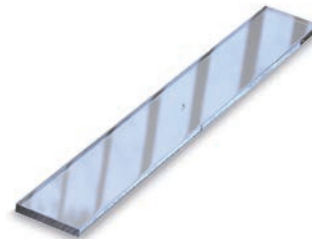

Holder



Fiber-optic cable connection

Interfaces

Evaluation electronics with integrated display

The evaluation electronics feature interfaces for encoders, for communication, and for external components.



	QC 2000	QC 3014 NC QC 3024 NC	ND 287	GAGE-CHEK 2000	ND 2104 G ND 2108 G
Encoders					
1 V _{PP} /11 μA _{PP}	●	●	●/●	●	●/-
TTL	●	●	-	●	●
EnDat 2.2. ¹⁾	●	●	●	●	●
Touch probe	-	SW option ²⁾	-	● ²⁾	-
Video	-	SW option ³⁾	-	-	-
Fiber-optic cable	SW option	SW option	-	-	-
Sensor ±10 V	-	-	Option	-	-
Data					
USB	Type A	Type A	Type B	Type A	Type A
RS-232-C/V.24	-	-	●	● ⁴⁾	●
Ethernet	●	●	Option	●	-
Light control	-	SW option	-	-	-
Zoom	-	-	-	-	-
CNC outputs	-	-	-	-	-
Foot switch	●	-	-	●	●
Operating pad	-	-	-	-	●
Switching outputs	1 TTL	22 TTL	6 TTL	1 TTL	12 TTL
Switching inputs	4 TTL	12 TTL	12 TTL	4 TTL	5 TTL

● = Available

- = Not available

1) Purely serial, no evaluation of incremental signals

2) HEIDENHAIN or Renishaw touch probe

3) Cameras from IDS Imaging Developing Systems GmbH with resolutions of up to 2 megapixels

4) Possible with RS-232 adapter connection via USB port

Optional assemblies for the ND 287

Various input and output assemblies are available for the evaluation unit

Second encoder input (option)

The ND 287 evaluation unit can be equipped with an optional second encoder input.

Encoder module

Input assembly for second encoder with $1 V_{PP}$ $11 \mu A_{PP}$ or EnDat 2.2 interface
ID 654017-01

Analog input (option)

Through an optional input assembly, the ND 287 digital readout can be equipped with an additional analog input for connecting a sensor. The input voltage range is interpolated 4096-fold; for a sensor with $\pm 10 V$, the resolution is therefore 5 mV. The analog module provides 5 V DC, 12 V DC, and 24 V DC as the power supply for the sensor.

The 5 V DC (B) and 12/24 V DC (A) are galvanically isolated. They must not be used at the same time. A 9-pin D-sub connector is required as mating connector.

Analog module

Input assembly for $\pm 10 V$ analog sensor
ID 654018-01

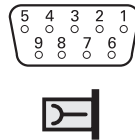

Pin	Assignment
1	-12 V (A)/85 mA
2	0 V (A)
3	0 V (A)
4	+12 V (A)/85 mA
5	Shield
6	0 V (B)
7	0 V (B)
8	Sensor (B) $\pm 10 V$ max.
9	+5 V (B)/400 mA

Ethernet (option)

The ND 287 evaluation unit can be equipped with an optional Ethernet module.

Ethernet module

ID 654019-01

This module is provided with an Ethernet 100BaseT interface with RJ45 connector (female, 8-pin). This enables you to connect the ND 287 directly to your company's intranet or, with a crossover cable, to a PC.

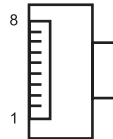

Pin	Assignment
1	TX+
2	TX-
3	REC+
4	Do not assign
5	Do not assign
6	REC-
7	Do not assign
8	Do not assign
Housing	External shield

IK 5000 evaluation unit



The IK 5000 has D-sub connectors for connection. Depending on the version, further connections are made through one, two, or three additional slot covers. Please order the adapter cables necessary between the individual components separately.

		IK 5293		IK 5294	IK 5394		IK 5493	IK 5494		IK 5594
	Slots ¹⁾	2	2	2	3	4	3	4	4	
	Position									
Encoders for X, Y, Z	IK	1 V _{PP} or TTL								
CNC outputs	IK	-	-	-	-	-	●	●	●	●
Foot switch	IK	●	●	●	●	●	●	●	●	●
Fiber-optic cable	Slot L	-	-	-	● ²⁾	-	● ²⁾	-	-	-
Touch probe³⁾	Slot 1	Simple	Universal	-	-	Simple	-	-	Simple	High-End (TP 200)
Light control	Slot 1	-	-	-	-	●	-	●	●	●
Encoder for Q	Slot 2	-	-	1 V _{PP} or TTL						
Zoom	Slot 3	-	-	-	-	●	-	●	●	●
Video	PC	-	-	-	-	USB camera, Ethernet camera ⁴⁾	-	USB camera, Ethernet camera ⁴⁾	USB camera, Ethernet camera ⁴⁾	USB camera, Ethernet camera ⁴⁾

● = Available; - = Not available

¹⁾ Including IK; ²⁾ Connected directly to the IK PCB, special slot cover with cable guide included in delivery

³⁾ HEIDENHAIN or Renishaw touch probe; ⁴⁾ Connected to the Ethernet port of the PC

Adapter cables		1 V _{PP}	TTL
Complete with 15-pin (1 V _{PP}) or 9-pin (TTL) D-sub connectors (female), and 3-pin mini-DIN connector (female) For connecting the XYZ encoders and the foot switch to the IK 5000			
	For 3 axes XYZ and foot switch	540550-40	540550-10
	For 2 axes XY and foot switch	540540-24	540540-05
Complete with 15-pin (1 V _{PP}) or 9-pin (TTL) D-sub connector (female) For connecting the Q encoder to the IK 5000		540541-24	540541-05

EIB 700, EIB 220 evaluation units

The EIB 700 and IK 220 evaluation units feature D-sub connectors for the connection of encoders and for external operation.

With the IK 220, the encoder signals can be sent out over an additional slot cover. They are available as 11 μA current signals for further processing in evaluation electronics or as EXE pulse-shaping electronics. A further slot cover contains the connections for the external inputs/outputs (e.g., for storing the measured values).

	EIB 700	IK 220
Encoder inputs		
1 V _{PP}	4 ¹⁾	2 ¹⁾
11 μA_{PP}	4 ¹⁾	2 ¹⁾
EnDat 2.1	4 ¹⁾	2 ¹⁾
EnDat 2.2	4 ¹⁾	–
SSI	–	2 ¹⁾
Encoder outputs		
11 μA_{PP}	–	2 (optional assembly)
Trigger input	4	2 (optional assembly)
Trigger output	4	2 (optional assembly)
PLC inputs/outputs	4/4 ²⁾	2/–

1) Selectable 2) Can also be used as a trigger or logical input or output

Accessories

External inputs/outputs for IK 220

Slot cover with two 9-pin D-sub connections (male)
ID 340253-01

Output assembly for IK 220

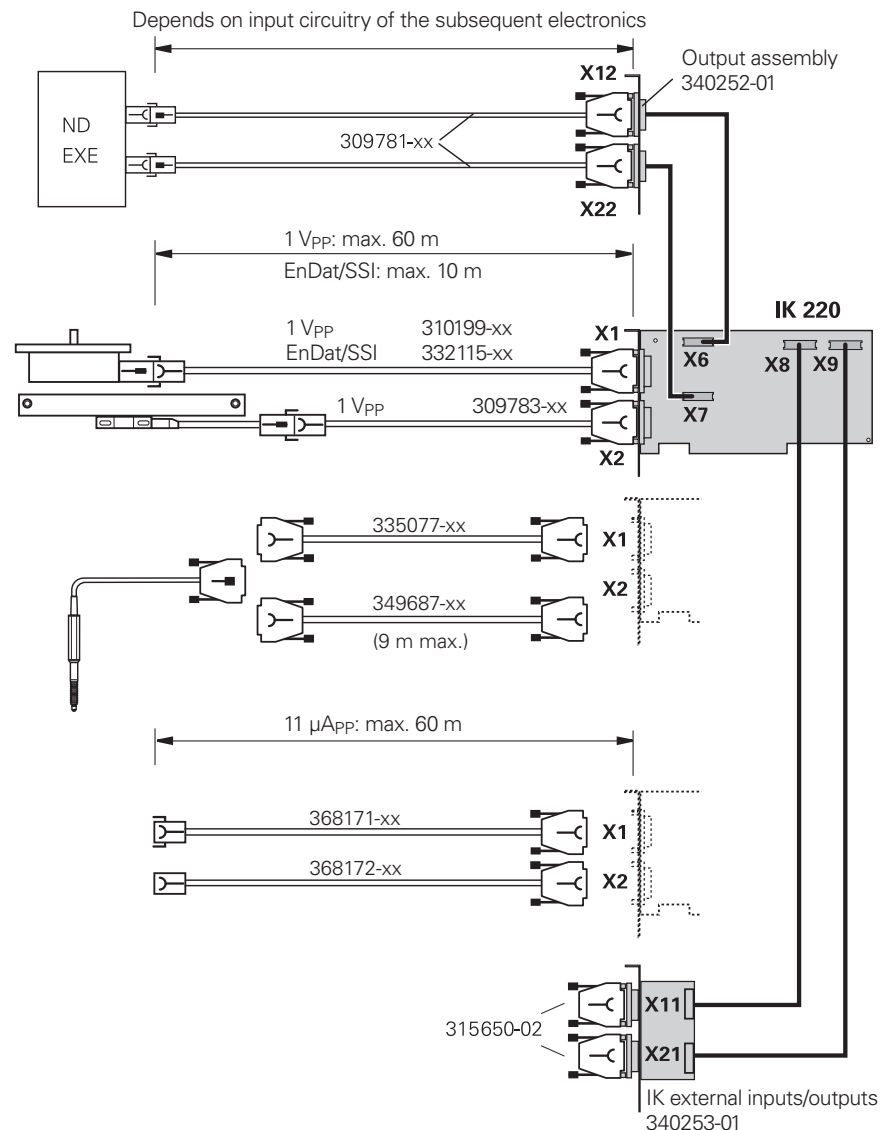

Slot cover with two 9-pin D-sub connections (male), for forwarding the encoder signals (11 μA_{PP}) to the subsequent electronics.
ID 340252-01



Encoder inputs

The evaluation units feature interfaces for connecting HEIDENHAIN encoders. Other interfaces are available upon request. A distribution cable is necessary in order to attach the encoders to the IK 5000.

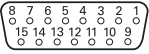
Pin layout $\sim 1V_{PP}$



15-pin D-sub flange socket (female)												
 												
	Power supply				Incremental signals						Others	
	4	12	2	10	1	9	3	11	14	7	5/6/8/ 13/15	
$\sim 1V_{PP}$	U_P	Sensor U_P	0V	Sensor 0V	A+	A-	B+	B-	R+	R-	/	
	●————●		●————●									

Cable shield connected to housing; U_P = Power supply voltage

Sensor: The sense line is connected in the encoder with the corresponding power line.

Vacant pins or wires must not be used!

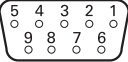

Pin layout \square TTL

9-pin D-sub flange socket (female)									
 									
	Power supply		Incremental signals						Others
	7	6	2	3	4	5	9	8	1
\square TTL	U_P	0V	U_{a1}	\overline{U}_{a1}	U_{a2}	\overline{U}_{a2}	U_{a0}	\overline{U}_{a0}	/

Cable shield connected to housing; U_P = Power supply voltage

Vacant pins or wires must not be used!

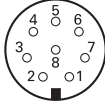

Pin layout of ND 2100G with EnDat

8-pin M12 flange socket								
								
Power supply				Serial data transfer				
	8	2	5	1	3	4	7	6
	U_P	Sensor U_P	0V	Sensor 0V	DATA	$\overline{\text{DATA}}$	CLOCK	$\overline{\text{CLOCK}}$
	●————●		●————●					

Cable shield connected to housing; U_P = Power supply voltage

Sensor: The sense line is connected in the encoder with the corresponding power line
Vacant pins or wires must not be used!

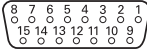



Pin layout of the ND 200, QUADRA-CHEK, and GAGE-CHEK series with $\sim 1V_{PP}/\sim 11\mu A_{PP}/\text{EnDat}$

15-pin D-sub flange socket (female)															
															
Power supply					Incremental signals							Serial data transfer			
	4	12	2	10	6	1	9	3	11	14	7	5	13	8	15
$\sim 1V_{PP}$	U_P	Sensor U_P	0V	Sensor 0V	/	A+	A-	B+	B-	R+	R-	/	/	/	/
$\sim 11\mu A_{PP}$	●————●		●————●		Internal shield	I_{1+}	I_{1-}	I_{2+}	I_{2-}	I_{0+}	I_{0-}	/	/	/	/
EnDat						/	/	/	/	/	/	DATA	$\overline{\text{DATA}}$	CLOCK	$\overline{\text{CLOCK}}$

Shield on housing; U_P = Power supply voltage

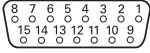
Sensor: the sense line is connected in the encoder with the corresponding power line
Vacant pins or wires must not be used!

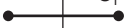
Pin layout of EIB 700 series with $\sim 1V_{PP}$

15-pin D-sub flange socket (female)														
 														
	Power supply				Incremental signals						Others			
	4	12	2	10	1	9	3	11	14	7	8	6	5/13/15	
$\sim 1V_{PP}$	U_P	Sensor U _P	0V	Sensor 0V	A+	A-	B+	B-	R+	R-	L1/H¹⁾	L2/L¹⁾	/	
														





Shield on housing; **U_P** = Power supply voltage

Sensor: the sense line is connected in the encoder with the corresponding power line

Vacant pins or wires must not be used!

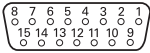
¹⁾ Pins for homing or limit signals if these are supported by the encoder

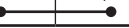
Pin layout of EIB 700 series with EnDat

15-pin D-sub flange socket (female)														
 														
	Power supply					Incremental signals ¹⁾				Serial data transfer				Others
	4	12	2	10	6	1	9	3	11	5	13	8	15	7/14
EnDat	U_P	Sensor U _P	0V	Sensor 0V	Internal shield	A+	A-	B+	B-	DATA	DATA	CLOCK	CLOCK	/
														



Shield on housing; **U_P** = Power supply voltage

Sensor: the sense line is connected in the encoder with the corresponding power line

Vacant pins or wires must not be used!

¹⁾ For encoders with ordering designations EnDat01 and EnDat02

Pin layout of IK 220

15-pin D-sub flange socket (male)															
															
	Power supply					Incremental signals						Serial data transfer			
	1	9	2	11	13	3	4	6	7	10	12	5	8	14	15
11 μ A _{PP}	U _P 5V	Sensor 5V	U _N 0V	Sensor 0V	Internal shield	I ₁ +	I ₁ -	I ₂ +	I ₂ -	I ₀ +	I ₀ -	/	/	/	/
1 V _{PP}	●—————●		●—————●			A+	A-	B+	B-	R+	R-	/	/	/	/
EnDat SSI						A+	A-	B+	B-	/	/	DATA	$\overline{\text{DATA}}$	CLOCK	$\overline{\text{CLOCK}}$

Shield on connector housing

Vacant pins or wires must not be used.

Switching inputs/outputs on the ND 287

Switching inputs

The ND 287 evaluation unit features many inputs for external operation and outputs for switching functions.

The input can be addressed via a pulse or closed contact.

Exception: the switching inputs for transmitting measured values over the data interface are separate for contact and pulse.

The switching input E is active when a Low signal U_L is applied (contact or pulse to 0 V).

Signal level

– $0.5\text{ V} \leq U_L \leq 0.9\text{ V}$ with $I_L \leq 6\text{ mA}$
 $3.9\text{ V} \leq U_H \leq 15.0\text{ V}$
 $t_{\min} \geq 30\text{ ms}$

Zero reset/preset

Each axis can be set by an external signal to the display value zero or to a value stored in a parameter (SET).

External control of measurement series Switching the display between MIN, MAX, or DIFF

With a continuously applied LOW signal at the corresponding switching input, you activate the external control of measurement series. Starting a measurement series and switching to the MIN/MAX/DIFF display are controlled externally over additional switching inputs.

Ignoring reference mark signals

(reference pulse lock)

When the input is active, the readout ignores all reference mark signals. A typical application is linear measurement over a rotary encoder and lead screw.

Activating or deactivating REF mode

After switch-on or a power interruption, the digital readout can be switched externally to REF mode. The next signal then deactivates REF mode (switchover function).

Display with axis coupling

As an option, the ND 287 can have two encoder inputs. Using switching inputs, you can switch the display to individual measured values, sum, difference, or any logical operation.

ND 287	
12 switching inputs	Reset, clear error message Set datum Ext. control of measurement series or display of $X1^{1)}$ Start measurement series or display of $f(X1, X2)^{1)}$ Display minimum MIN or display of $X2^{1)}$ Display maximum MAX or display of $X1 + X2^{1)}$ Display difference DIFF or display of $X1 - X2^{1)}$ Measured value output (pulse) Measured value output (contact) Ignore reference mark signals (input X1) Ignore reference mark signals (input X2) Activating or deactivating REF mode
6 switching outputs	Display value is zero Measured value switching limit A1 Measured value \leq switching limit A2 Measured value $>$ upper sorting limit Measured value $<$ lower sorting limit Error

¹⁾ Also selectable by parameter

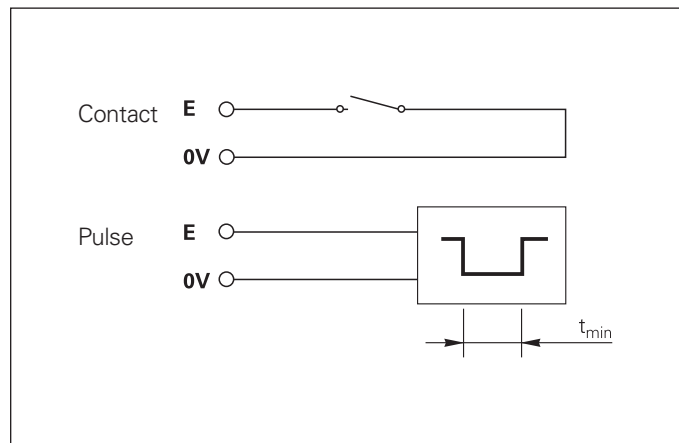

Switching outputs

The ND 287 features open-collector outputs that switch to 0 V (= active LOW).

Delay of signal output:

$t_v \leq 20 \text{ ms}$

Signal level

$U_L \leq 0.4 \text{ V}$ with $I_L \leq 100 \text{ mA}$
 $U_H \leq 32 \text{ V}$ with $I_H \leq 10 \mu\text{A}$

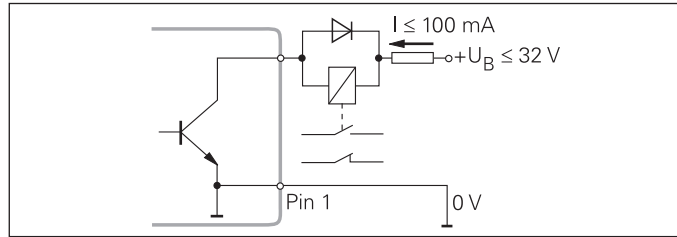

Trigger points (in actual value mode)

When the measured value reaches trigger points defined by parameters, the corresponding output becomes active. Up to two trigger points can be defined.

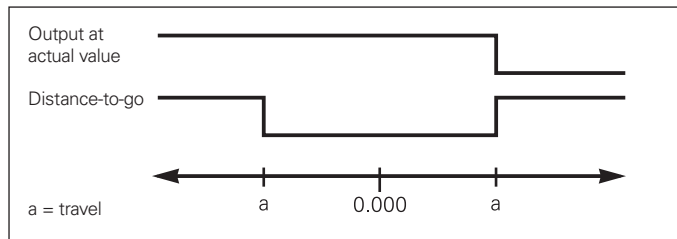

Switch-off ranges (distance-to-go mode)

In the distance-to-go mode the trigger points function as switch-off ranges. They are located symmetrically around the display value 0.

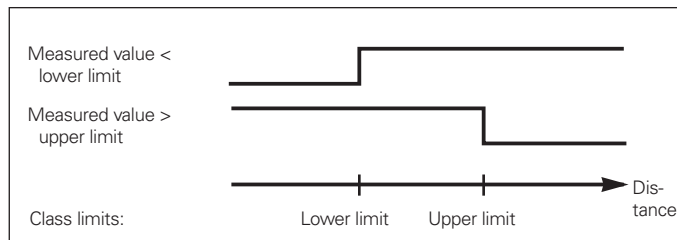

Sorting limits

When the measured value exceeds the limits defined via parameters, the corresponding outputs become active.

Trigger signal for error

The ND 200 series readouts constantly monitor the measuring signals, the input frequency, the data output, etc., for errors, and report errors as they occur with error messages. If errors occur that may distort the measurement or corrupt the data, the readout activates a switching output. This feature allows the monitoring of automated processes.

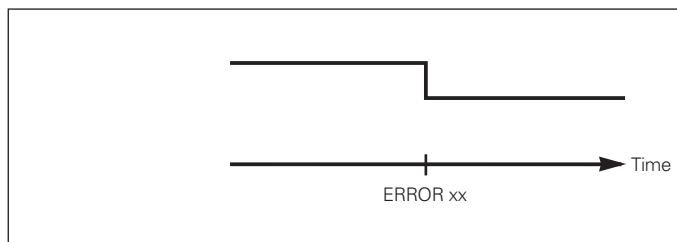

Zero crossover

At the display value "zero," the corresponding output becomes active. The minimum signal duration is 180 ms.

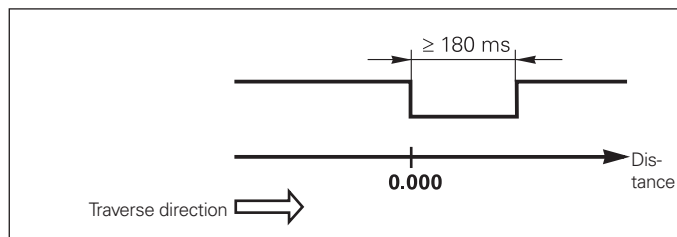

Software

QUADRA-CHEK Wedge

QUADRA-CHEK Wedge software

For communication between the ND 280/287 or ND 2000 and the PC ID 709141-01

The QUADRA-CHEK Wedge software simplifies communication between an ND 280/287 or ND 2000 and a Windows-based PC. The measured values are transmitted from the evaluation unit to the PC via an RS-232-C connection and are written directly to an Excel table, where the data can be edited, saved, and printed. The software can be downloaded at no charge from www.heidenhain.de ► Software

System requirements

- Windows XP, Vista, 7, 8, or 10 (32-bit/64-bit)
- Internet Explorer 6.0 or higher
- Excel 2003 or later
- Windows user rights: Administrator

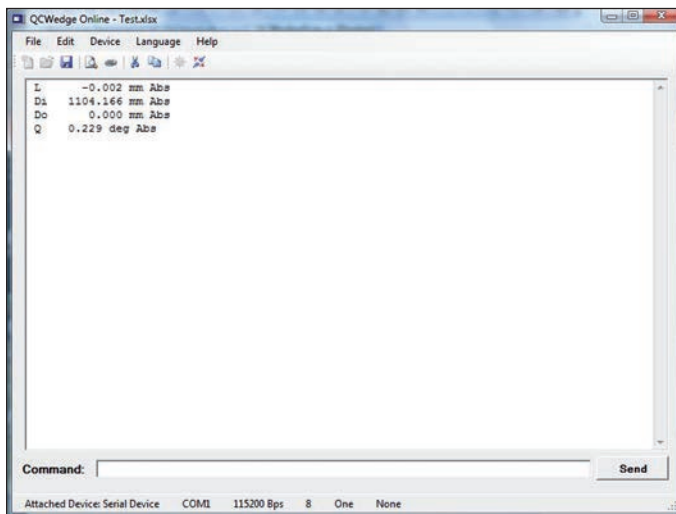

The values acquired by the evaluation electronics are transmitted to the PC ...

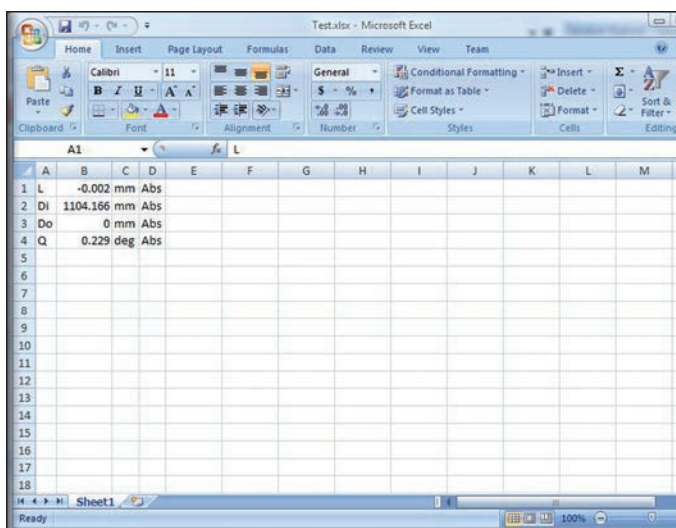

... and can be saved in an Excel table.

EIB 700 application software

The EIB application software covers two applications:

Commissioning and demonstration of the EIB 700

- Easy configuration of settings required for operation of the EIB 700 (e.g., input interface, data packets, operating mode, trigger settings).
- Management of one or more EIB 700 units.
- Simple representation of the positions transmitted by the EIB 700.
- Settings can be saved so that different application projects can be managed.

The user's guide provides more information.

Platform for customer applications

The EIB application software is made available in the source code. With this application as a basis, customers can rapidly implement their own applications. The application software was programmed using C++/CLI and Windows Forms in Visual Studio 2008. This programming environment is widely used in technical application programming but does not necessarily provide state-of-the-art operating techniques like those in Windows 10, for example. However, the customer can adapt the program to other graphic user interfaces.

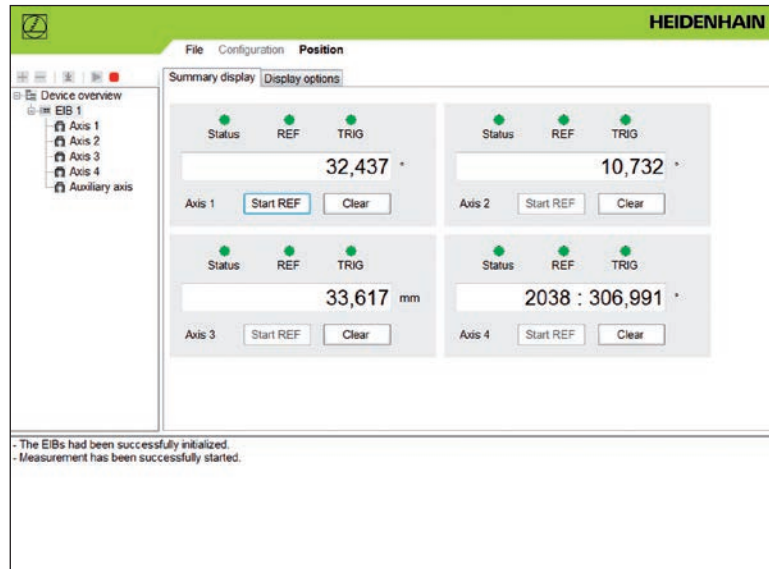

HEIDENHAIN

DR. JOHANNES HEIDENHAIN GmbH

Dr.-Johannes-Heidenhain-Straße 5

83301 Traunreut, Germany

☎ +49 8669 31-0

FAX +49 8669 32-5061

E-mail: info@heidenhain.de

www.heidenhain.de

Vollständige und weitere Adressen siehe www.heidenhain.de
For complete and further addresses see www.heidenhain.de

DE	HEIDENHAIN Vertrieb Deutschland 83301 Traunreut, Deutschland ☎ 08669 31-3132 FAX 08669 32-3132 E-Mail: hd@heidenhain.de	ES	FARRESA ELECTRONICA S.A. 08028 Barcelona, Spain www.farresa.es	PH	MACHINEBANKS' CORPORATION Quezon City, Philippines 1113 E-mail: info@machinebanks.com
	HEIDENHAIN Technisches Büro Nord 12681 Berlin, Deutschland ☎ 030 54705-240	FI	HEIDENHAIN Scandinavia AB 01740 Vantaa, Finland www.heidenhain.fi	PL	APS 02-384 Warszawa, Poland www.heidenhain.pl
	HEIDENHAIN Technisches Büro Mitte 07751 Jena, Deutschland ☎ 03641 4728-250	FR	HEIDENHAIN FRANCE sarl 92310 Sèvres, France www.heidenhain.fr	PT	FARRESA ELECTRÓNICA, LDA. 4470 - 177 Maia, Portugal www.farresa.pt
	HEIDENHAIN Technisches Büro West 44379 Dortmund, Deutschland ☎ 0231 618083-0	GB	HEIDENHAIN (G.B.) Limited Burgess Hill RH15 9RD, United Kingdom www.heidenhain.co.uk	RO	HEIDENHAIN Reprezentantă Romania Braşov, 500407, Romania www.heidenhain.ro
	HEIDENHAIN Technisches Büro Südwest 70771 Leinfelden-Echterdingen, Deutschland ☎ 0711 993395-0	GR	MB Milionis Vassilis 17341 Athens, Greece www.heidenhain.gr	RS	Serbia → BG
	HEIDENHAIN Technisches Büro Südost 83301 Traunreut, Deutschland ☎ 08669 31-1337	HK	HEIDENHAIN LTD Kowloon, Hong Kong E-mail: sales@heidenhain.com.hk	RU	OOO HEIDENHAIN 115172 Moscow, Russia www.heidenhain.ru
		HR	Croatia → SL	SE	HEIDENHAIN Scandinavia AB 12739 Skärholmen, Sweden www.heidenhain.se
		HU	HEIDENHAIN Kereskedelmi Képviselet 1239 Budapest, Hungary www.heidenhain.hu	SG	HEIDENHAIN PACIFIC PTE LTD Singapore 408593 www.heidenhain.com.sg
AR	NAKASE SRL. B1653AOX Villa Ballester, Argentina www.heidenhain.com.ar	ID	PT Servitama Era Toolsindo Jakarta 13930, Indonesia E-mail: ptset@group.gts.co.id	SK	KOPRETINA TN s.r.o. 91101 Trenčin, Slovakia www.kopretina.sk
AT	HEIDENHAIN Techn. Büro Österreich 83301 Traunreut, Germany www.heidenhain.de	IL	NEUMO VARGUS MARKETING LTD. Holon, 58859, Israel E-mail: neumo@neumo-vargus.co.il	SL	NAVO d.o.o. 2000 Maribor, Slovenia www.heidenhain.si
AU	FCR MOTION TECHNOLOGY PTY LTD Laverton North Victoria 3026, Australia E-mail: sales@fcrmotion.com	IN	HEIDENHAIN Optics & Electronics India Private Limited Chetpet, Chennai 600 031, India www.heidenhain.in	TH	HEIDENHAIN (THAILAND) LTD Bangkok 10250, Thailand www.heidenhain.co.th
BE	HEIDENHAIN N.V. 1760 Roosdaal, Belgium www.heidenhain.be	IT	HEIDENHAIN ITALIANA S.r.l. 20128 Milano, Italy www.heidenhain.it	TR	T&M Mühendislik San. ve Tic. LTD. ŞTİ. 34775 Y. Dudullu – Umraniye-Istanbul, Turkey www.heidenhain.com.tr
BG	ESD Bulgaria Ltd. Sofia 1172, Bulgaria www.esd.bg	JP	HEIDENHAIN K.K. Tokyo 102-0083, Japan www.heidenhain.co.jp	TW	HEIDENHAIN Co., Ltd. Taichung 40768, Taiwan R.O.C. www.heidenhain.com.tw
BR	HEIDENHAIN Brasil Ltda. 04763-070 – São Paulo – SP, Brazil www.heidenhain.com.br	KR	HEIDENHAIN Korea LTD. Gasan-Dong, Seoul, Korea 153-782 www.heidenhain.co.kr	UA	Gertner Service GmbH Büro Kiev 02094 Kiev, Ukraine www.heidenhain.ua
BY	GERTNER Service GmbH 220026 Minsk, Belarus www.heidenhain.by	MX	HEIDENHAIN CORPORATION MEXICO 20290 Aguascalientes, AGS., Mexico E-mail: info@heidenhain.com	US	HEIDENHAIN CORPORATION Schaumburg, IL 60173-5337, USA www.heidenhain.com
CA	HEIDENHAIN CORPORATION Mississauga, Ontario L5T2N2, Canada www.heidenhain.com	MY	ISOSERVE SDN. BHD. 43200 Balakong, Selangor E-mail: sales@isoserve.com.my	VN	AMS Co. Ltd HCM City, Vietnam E-mail: davidgoh@amsvn.com
CH	HEIDENHAIN (SCHWEIZ) AG 8603 Schwerzenbach, Switzerland www.heidenhain.ch	NL	HEIDENHAIN NEDERLAND B.V. 6716 BM Ede, Netherlands www.heidenhain.nl	ZA	MAFEMA SALES SERVICES C.C. Midrand 1685, South Africa www.heidenhain.co.za
CN	DR. JOHANNES HEIDENHAIN (CHINA) Co., Ltd. Beijing 101312, China www.heidenhain.com.cn	NO	HEIDENHAIN Scandinavia AB 7300 Orkanger, Norway www.heidenhain.no		
CZ	HEIDENHAIN s.r.o. 102 00 Praha 10, Czech Republic www.heidenhain.cz	NZ	Llama ENGINEERING Ltd 5012 Wellington, New Zealand E-mail: info@llamaengineering.co.nz		
DK	TPTEKNIK A/S 2670 Greve, Denmark www.tp-gruppen.dk				

